

Data Sheet

Customer: _____

Product: Thick Film Chip Resistor. Automotive Grade HWF Series

Size : 0402/0603/0805/1206/1210/2010/2512

Issued Date: 30-Apr.-2015

Edition: Ver. 1

Record of change

Date	Ver.	Description	Page
30-Apr.-2015	1		

HITANO ENTERPRISE CORP.

7F-7, No. 3, Wu Chuan 1st Road, New Taipei Industrial Park,
New Taipei City, TAIWAN, R.O.C.

Tel: +886 2 2299 1331 (Rep.)

Fax: +886 2 2298 2466, 2298 2969

Prepared by	Checked by	Approved by	Accepted by (customer)
30-Apr.-2015	30-Apr.-2015	30-Apr.-2015	
<i>Andy Hsu</i>	<i>Hwa Wu</i>	<i>Hwa Wu</i>	

THICK FILM CHIP RESISTORS

HWF SERIES

■ Feature

- Meet AEC-Q200 test for Automotive industry.
- Highly reliable multilayer electrode
- Compatible with all soldering process
- Rohs & REACH compliant

■ Construction

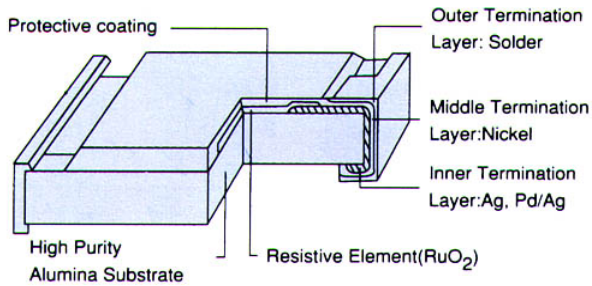

■ Part Numbering:

HWF 0805 F R = 100R

Size 0402 0603 0805 1206 1210 2012 2512	Tolerance F=±1% J=±5%	Packing style R = Paper K = Embossed Plastic	Special Type - = 7 inch Dia. Reel (Standard) 10 = 10 inch Reel (non preferred) 13 = 13 inch Reel	Resistance Value for example 1R 10KR 10R 100KR 100R 1MR 1KR 10MR
--	-----------------------------	---	---	---

■ Resistance Marking

No Marking	Value=10 KΩ	Value=10 KΩ	Value=12.4 KΩ	E-24 1% Value=56 K
0402	5% marking 0603 0805 1206 1210 2010 2512	1% marking 0805 1206 1210 2010 2512	1% marking for 0603 EIA-96 series items	1% marking for 0603 EIA-24 series items

Marking explanation

- 5% tolerance: 3 digits, first two digits are significant figures, third digit is number of zeros.
- 1% tolerance: 4 digits. First three digits are significant figures, fourth digit is number of zeros,
- Letter R is decimal point.
- RC0603 1% : EIA-96 marking at following page, when values in E-24 series marking as last column of above

THICK FILM CHIP RESISTORS

HWF SERIES

General Specification

■ Dimension (mm)

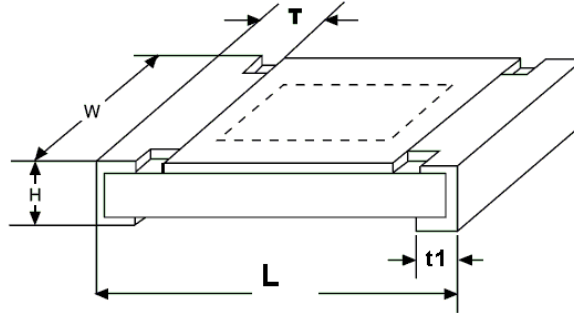

EIA Size	Power Rating (at 70°C)	L	W	H	T	t ₁
0402	1/16W	1.0±0.10	0.5±0.05	0.30±0.05	0.20±0.10	0.25±0.10
0603	1/10W	1.6±0.10	0.8±0.10	0.45±0.10	0.25±0.15	0.25±0.15
0805	1/8W	2.0±0.10	1.20±0.10	0.55±0.10	0.35±0.20	0.35±0.20
1206	1/4W	3.1±0.15	1.55±0.15	0.55±0.10	0.45±0.20	0.40±0.20
1210	1/3W	3.1±0.15	2.60±0.15	0.55±0.10	0.50±0.20	0.50±0.20
2010	3/4W	5.0±0.15	2.50±0.15	0.55±0.10	0.60±0.20	0.50±0.20
2512	1W	6.4±0.15	3.20±0.15	0.55±0.10	0.60±0.20	0.50±0.20

■ Rating

SIZE	Power Rating	Max W.V.	Max Over Load Volt	Tol. (%)	Resistance Range (Ω)	TCR ppm/°C	Normal Res. Value
0402	1/16W	50V	100V	±5	0R, 1Ω~10MΩ	100 ppm/°C for range 10~1MΩ	E-24 for 5% E-96 for 1%
				±1	1Ω~10MΩ		
0603	1/10W	50V	100V	±5	0R, 1Ω~20MΩ	200 ppm/°C for range 1Ω ≤ R < 10Ω, 1MΩ < R ≤ 20MΩ	E-24 for 5% E-96 for 1%
				±1	1Ω~10MΩ		
0805	1/8W	150V	300V	±5	0R, 1Ω~20MΩ	100 ppm/°C for range 10~1MΩ	E-24 for 5% E-96 for 1%
				±1	1Ω~10MΩ		
1206	1/4W	200V	400V	±5	0R, 1Ω~20MΩ	200 ppm/°C for range 1Ω ≤ R < 10Ω, 1MΩ < R ≤ 20MΩ	E-24 for 5% E-96 for 1%
				±1	1Ω~10MΩ		
1210	1/3W	200V	400V	±5	0R, 1Ω~20MΩ	100 ppm/°C for range 10~1MΩ	E-24 for 5% E-96 for 1%
				±1	1Ω~10MΩ		
2010	3/4W	200V	400V	±5	0R, 1Ω~20MΩ	200 ppm/°C for range 1Ω ≤ R < 10Ω, 1MΩ < R ≤ 20MΩ	E-24 for 5% E-96 for 1%
				±1	1Ω~10MΩ		
2512	1W	250V	500V	±5	0R, 1Ω~20MΩ	100 ppm/°C for range 10~1MΩ	E-24 for 5% E-96 for 1%
				±1	1Ω~10MΩ		

Operating Temp. Range : -55 ~ +155°C

Power Rating at 70°C

Jumper: R_{max} < 50mΩ, Rated current I_R ≤ 2A (0402, 0603 size ≤ 1A)

THICK FILM CHIP RESISTORS

HWF SERIES

Derating Curve

For resistors operated in ambient temperatures above 70°C, power rating just be derated in accordance with curve below.

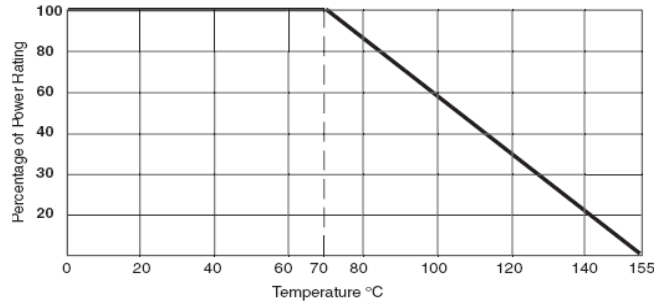

0603 1% Marking Table

Code	E48	E96	Code	E48	E96	Code	E48	E96	Code	E48	E96
01	100	100	25	178	178	49	316	316	73	562	562
02		102	26		182	50		324	74		576
03	105	105	27	187	187	51	332	332	75	590	590
04		107	28		191	52		340	76		604
05	110	110	29	196	196	53	348	348	77	619	619
06		113	30		200	54		357	78		634
07	115	115	31	205	205	55	365	365	79	649	649
08		118	32		210	56		374	80		665
09	121	121	33	215	215	57	383	383	81	681	681
10		124	34		221	58		392	82		698
11	127	127	35	226	226	59	402	402	83	715	715
12		130	36		232	60		412	84		732
13	133	133	37	237	237	61	422	422	85	750	750
14		137	38		243	62		432	86		768
15	140	140	39	249	249	63	442	442	87	787	787
16		143	40		255	64		453	88		806
17	147	147	41	261	261	65	464	464	89	825	825
18		150	42		267	66		475	90		845
19	154	154	43	274	274	67	487	487	91	866	866
20		158	44		280	68		499	92		887
21	162	162	45	287	287	69	511	511	93	909	909
22		165	46		294	70		523	94		931
23	169	169	47	301	301	71	536	536	95	953	953
24		174	48		309	72		549	96		976

This table shows the first two digits for the 3 digits EIA-96 part marking scheme.

The 3rd character is a letter multiplier : Y=10⁻², X=10⁻¹, A=10⁰, B=10¹, C=10², D=10³, E=10⁴, F=10⁵

THICK FILM CHIP RESISTORS

HWF SERIES

■ Specification & Test Method according to AEC-Q200 TABLE 7

ITEM	SPECIFICATION	TEST METHOD
DC Resistance	J: $\pm 5\%$, F: $\pm 1\%$ Zero ohm Jumper < 50m Ω	IEC 60115-1 / JIS C 5201-1 , Clause 4.5 Measure the resistance value.
Short time Overload	J: $\Delta R \leq \pm (1\% + 0.1\Omega)$ F: $\Delta R \leq \pm (0.5\% + 0.05\Omega)$	IEC 60115-1 / JIS C 5201-1 , Clause 4.13 2.5×Rated voltage or Max. Overload Voltage for 5 sec. measure resistance after 30 minutes
Temperature Coefficient of Resistance (TCR)	F: $\pm 100 \text{ ppm}/^\circ\text{C}$ J: $\pm 200 \text{ ppm}/^\circ\text{C}$	IEC 60115-1 / JIS C 5201-1 , Clause 4.8 Test temperature : 25 $^\circ\text{C}$ (T1) \rightarrow -55 $^\circ\text{C}$ (T2) 25 $^\circ\text{C}$ (T1) \rightarrow +155 $^\circ\text{C}$ (T2) $\text{TCR (ppm}/^\circ\text{C)} = \frac{R2-R1}{R1} \times \frac{1}{T2-T1} \times 10^6$ T1: 25 $^\circ\text{C}$ T2: Test temperature R1: Resistance at reference temperature (T1) R2: Resistance at test temperature (T2)
High Temperature Exposure (Storage)	J: $\Delta R \leq \pm (3\% + 0.1\Omega)$ F: $\Delta R \leq \pm (1\% + 0.05\Omega)$	AEC-Q200 TABLE 7.3 1000 hrs. @ T=125 $^\circ\text{C}$. Unpowered. Measurement at 24 \pm 2 hours after test conclusion.
Temperature Cycle	J: $\Delta R \leq \pm (1\% + 0.1\Omega)$ F: $\Delta R \leq \pm (0.5\% + 0.05\Omega)$ No mechanical damage	IEC 60115-1 / JIS C 5201-1 , Clause 4.19 Repeat 1000 cycles as follows -55 $^\circ\text{C}$ (30 min.) + 25 $^\circ\text{C}$ (2~3 min.) +125 $^\circ\text{C}$ (30 min.) + 25 $^\circ\text{C}$ (2~3 min.)
Moisture Resistance	J: $\Delta R \leq \pm (1\% + 0.1\Omega)$ F: $\Delta R \leq \pm (0.5\% + 0.05\Omega)$	AEC-Q200 TABLE 7.6 t = 24 hours/cycle. Note: Steps 7a & 7b not required. Unpowered. Measurement at 24 \pm 2 hours after test conclusion.
Biased Humidity	J: $\Delta R \leq \pm (3\% + 0.1\Omega)$ F: $\Delta R \leq \pm (1\% + 0.05\Omega)$	AEC-Q200 TABLE 7.7 1000 hours 85 $^\circ\text{C}$ /85%RH. Note: Specified conditions: 10% of operating power. Measurement at 24 \pm 2 hours after test conclusion.
Operational Life	J: $\Delta R \leq \pm (3\% + 0.1\Omega)$ F: $\Delta R \leq \pm (1\% + 0.05\Omega)$	AEC-Q200 TABLE 7.8 Condition D Steady State TA=125 $^\circ\text{C}$ at rated power. Measurement at 24 \pm 2 hours after test
Resistance to Solvents	No mechanical damage	AEC-Q200 TABLE 7.12 Add Aqueous wash chemical - OKEM Clean or equivalent. Do not use banned solvents.
Vibration	No mechanical damage	AEC-Q200 TABLE 7.14 5 g's for 20 min., 12 cycles each of 3 orientations. Note: Use 8"X5" PCB .031" thick 7 secure points on one long side and 2 secure points at corners of opposite sides. Parts mounted within 2" from any secure point. Test from 10-2000 Hz.
Resistance to Solder Heat	J: $\Delta R \leq \pm (1\% + 0.1\Omega)$ F: $\Delta R \leq \pm (0.5\% + 0.05\Omega)$ No mechanical damage	AEC-Q200 TABLE 7.15 Condition B No pre-heat of samples. Note: Single Wave Solder - Procedure 2 for SMD and Procedure 1 for Leaded with solder within 1.5mm of device
Thermal Shock	J: $\Delta R \leq \pm (1\% + 0.1\Omega)$ F: $\Delta R \leq \pm (0.5\% + 0.05\Omega)$ No mechanical damage	AEC-Q200 TABLE 7.16 -55 $^\circ\text{C}$ /+125 $^\circ\text{C}$. Note: Number of cycles required-300, Maximum transfer time-20 seconds, Dwell time-15 minutes. Air-Air

THICK FILM CHIP RESISTORS

HWF SERIES

■ Specification & Test Method according to AEC-Q200 TABLE 7

ITEM	SPECIFICATION	TEST METHOD
Solderability	Over 95% of termination must be covered with Solder	AEC-Q200 TABLE 7.18 For SMD. Electrical test not required. Magnification 50X. Conditions: SMD: a) Method B, 4 hrs @ 155 °C dry heat @ 235°C b) Method B @ 215°C category 3.
Load Life Humidity	J: $\Delta R \leq \pm (3\% + 0.1\Omega)$ F: $\Delta R \leq \pm (1\% + 0.05\Omega)$	IEC 60115-1 / JIS C 5201-1 , Clause 4.24 Maintain the temperature of the resistor at $40\pm 2^\circ\text{C}$ and 90~95% R.H. with the rated voltage applied. Cycle ON for 1.5 hours and OFF for 0.5 hour for 1000+48/-0 hours. After 1~4 hour, measure the resistance value
Load Life	J: $\Delta R \leq \pm (3\% + 0.1\Omega)$ F: $\Delta R \leq \pm (1\% + 0.05\Omega)$	IEC 60115-1 / JIS C 5201-1 , Clause 4.25 Permanent resistance change after 1000+48/-0 hours (1.5 hours ON , 0.5 hour OFF) at RCWV or Max Keep the resistor at $70\pm 2^\circ\text{C}$ ambient
Terminal Strength (SMD)	No mechanical damage	AEC-Q200 TABLE 7.22 Appendix 1 Note: Force of 1.8kg for 60 seconds.
Board Flex	J: $\Delta R \leq \pm (1\% + 0.1\Omega)$ F: $\Delta R \leq \pm (0.5\% + 0.05\Omega)$ No mechanical damage	AEC-Q200 TABLE 7.21 Appendix 2 Note: 2mm (Min)
Flammability	UL-94	AEC-Q200 TABLE 7.20 UL-94 V-0 or V-1 are acceptable

THICK FILM CHIP RESISTORS

HWF SERIES

■ Packaging

REEL DIMENSION (mm)

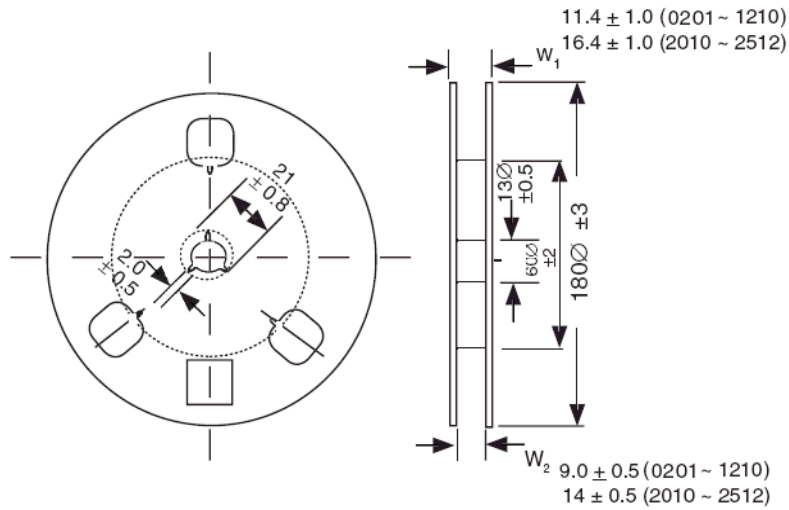

PAPER TAPE DIMENSIONS (mm)

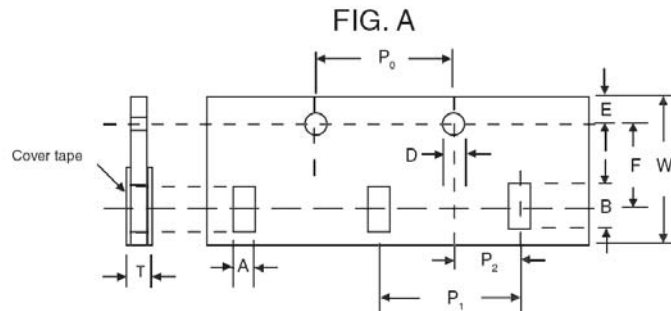

Size	A	B	D	E	F	P ₀	P ₁	P ₂	W	T
0201	0.45±0.1	0.75±0.1	1.5+0.1/-0	1.75±0.1	3.50±0.05	4.0±0.1	2.0±0.05	2±0.05	8±0.1	0.35±0.1
0402	0.65±0.1	1.15±0.1								0.53±0.1
0603	1.10±0.1	1.90±0.1								0.70±0.1
0805	1.65±0.1	2.40±0.1					4.0±0.05			0.85±0.1
1206	1.90±0.1	3.50±0.1								
1210	2.80±0.1	3.50±0.1								

THICK FILM CHIP RESISTORS

HWF SERIES

EMBOSSED TAPE DIMENSIONS (mm)

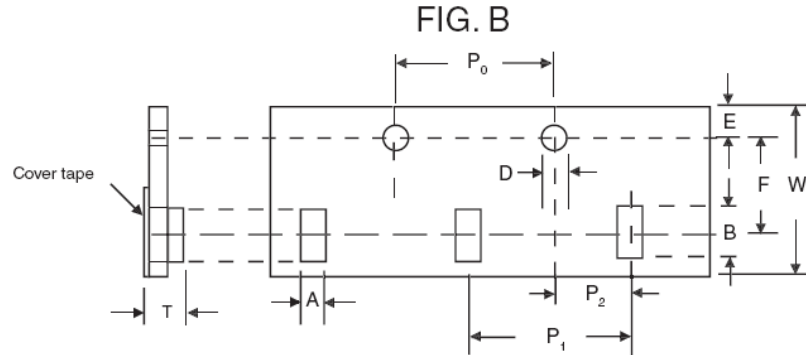

Size	A	B	D	E	F	P ₀	P ₁	P ₂	W	T
2010	2.80±0.2	5.40±0.2	1.5+0.1/-0	1.75±0.1	5.50±0.05	4.0±0.1	4.0±0.1	2±0.05	12.±0.3	1.0±0.1
2512	3.50±0.2	6.7±0.2								

■ Packing Q'TY

Reel Size	7 inches Reel	10 inches Reel	13 inches Reel
0201	10,000	20,000	50,000
0402	10,000	20,000	50,000
0603	5,000	10,000	20,000
0805	5,000	10,000	20,000
1206	5,000	10,000	20,000
1210	5,000	-	20,000
*2010	4,000	-	-
*2512	4,000	-	-

* Embossed Tape

■ Soldering Temperature Curve

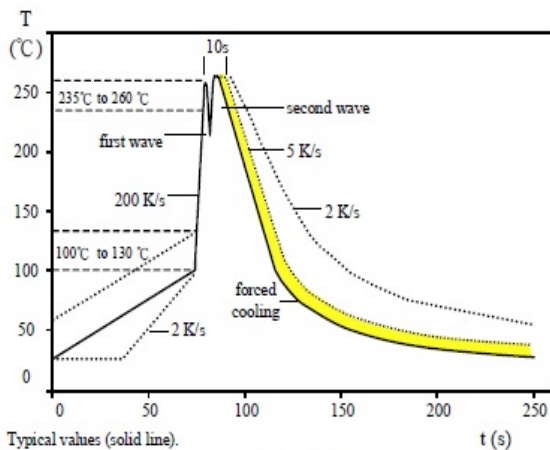

Typical values (solid line).

Process limits (dotted line).

WAVE soldering.

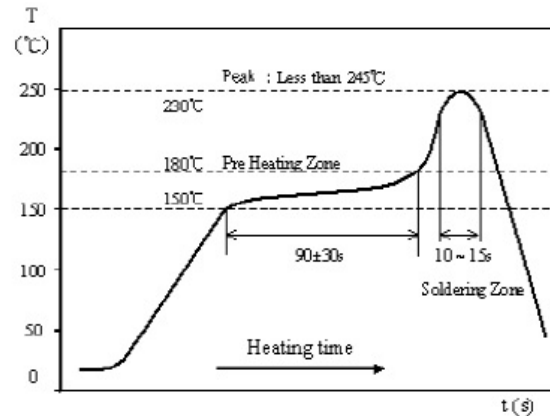

IR Reflow Soldering