

D6F-D

MEMS 2-Axis Flow Sensor

Dual sensing elements in a compact package realizes 2-Axis flow sensing.

- MEMS precision technology for flow velocity and flow direction sensing.
- Visualize wider area of flow distribution with Daisy-Chain connection.
- Precision 2-Axis flow velocity sensing with $\pm 3\%$ F.S. of accuracy.
- Fully integrated RS-485 digital interface.
- RoHS Compliant.



Ordering Information

Description	Case	Applicable Medium	Flow Range	Model
MEMS 2-Axis Flow Sensor	PC and PBT	Air (See note.)	$\pm 1.0\text{m/s}$	D6F-D010A32-00

Note: Dry gas must not contain large particles, eg dust, oil, mist.

Ratings

■ Absolute maximum rating ($T_a = 25^\circ\text{C}$)

Item	Symbol	Rating	Unit
Power-supply Voltage	V_{CC}	5.6	VDC
Common Mode I/O voltage	V_{CM}	-8 to 13	VDC

■ Electrical Performance

Item	Symbol	Condition	MIN	MAX	Unit
Power-supply Voltage	V_{CC}	-	4.5	5.5	V
Current Consumption	I_{CON}	No load	-	30	mA
Common mode output voltage (See note.)	V_{OC}	$R_L = 100\ \Omega$	-	3.0	V
Differential input threshold (See note.)	V_{TH}	$-7 < V_{CM} < 12$	-200	-50	mV

Note: Digital Interface TRD (-) and TRD (+).

■ Operating and Storage Condition

Item	Rating
Storage Temperature	-10 to $+55^\circ\text{C}$ (without freezing and condensation)
Operating Temperature	0 to $+40^\circ\text{C}$ (without freezing and condensation)
Storage Humidity	30 to 85%RH (without freezing and condensation)
Operating Humidity	30 to 85%RH (without freezing and condensation)

Characteristic

Item		Characteristic
Flow Velocity	Range	±1.0m/s in each axis
	Accuracy	±3%F.S. in each axis
Flow Direction	Range	0 to 360°
	Accuracy	±15° (at 0.3m/s)

Note: 1. Flow velocity is determined by our standard wind tunnel (300 mm square), and this does not indicate the flow velocity specified in Measurement law. (Fig.1 shows our standard wind tunnel)

Note: 2. Measurement condition:

- Power-supply Voltage: 5 VDC
- Device orientation: Horizontal mounting (top cover side up)
- Ambient temperature: 25±5°C
- Ambient humidity: 40 to 70%RH

Fig. 1.

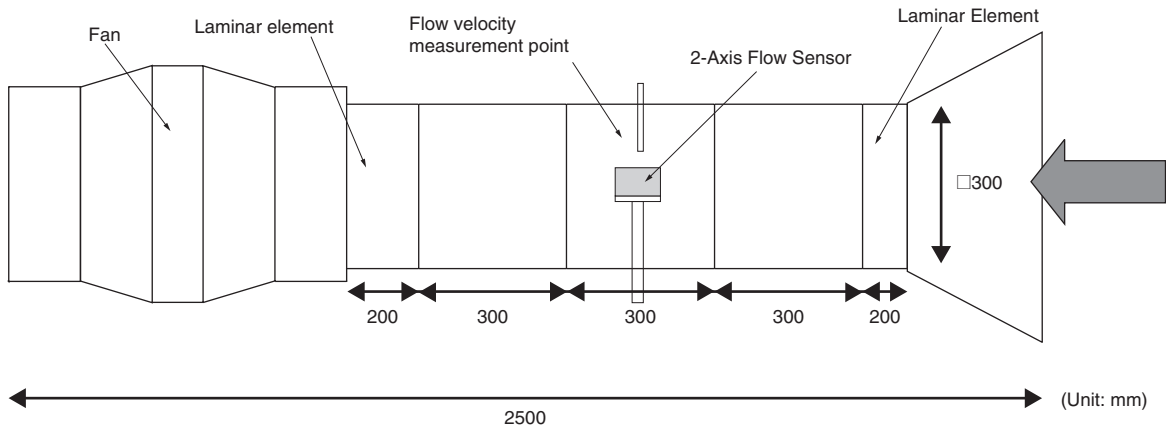

Connection

Fig. 2. Block Diagram

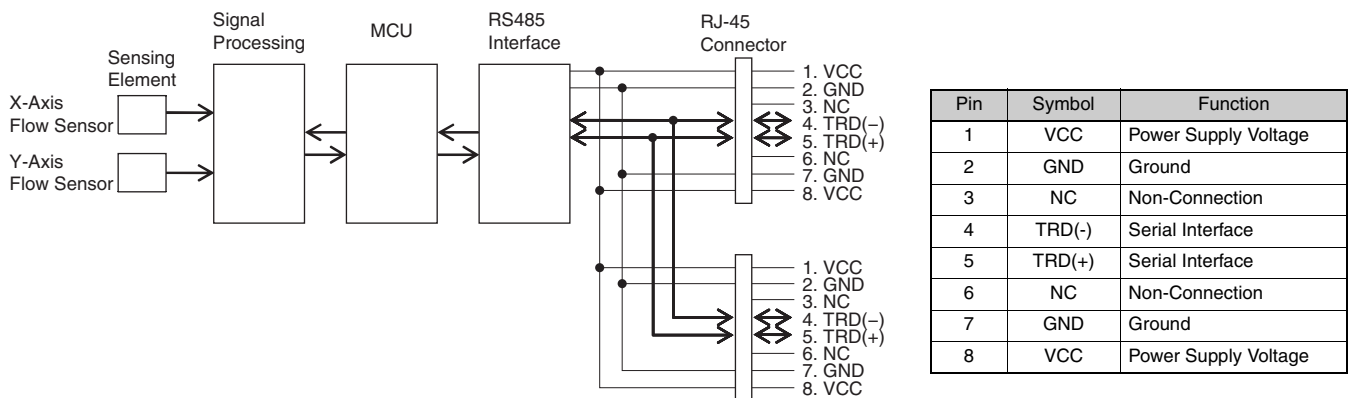

The sensor has two port of RJ-45 connectors (8 pins), and all the pair of each pin is connected internally.

These connectors can be used for daisy chain wiring when using multiple devices on the same bus (multi-drop connection).

The standard CAT5e straight LAN cable can be used for the electrical connection.

Interface

Item	Specifications
Interface	RS-485
Wire Connection	Multi-drop connection with daisy chain wiring (32 devices max.)
Communication system	2 wires : Half duplex
Baud rate	9600bps or 38400bps : DIP switch* selectable
Protocol	Modbus-RTU
Transmission code	Binary
Data length	8 bit
Stop bit	1 bit
Parity	None
Response time	250 ms max.
Command interval	10 ms min. (Minimum wait time after receiving the response from the device to the consecutive command transmission)
Slave address	1 to 32 (0x01 to 0x20) : DIP switch* selectable
Termination resistor	Built-in termination resistor : DIP switch* selectable

* The communication settings of this device can be set by DIP switch configuration as shown in Fig. 3.
All bits are switched off before shipment.

Fig. 3

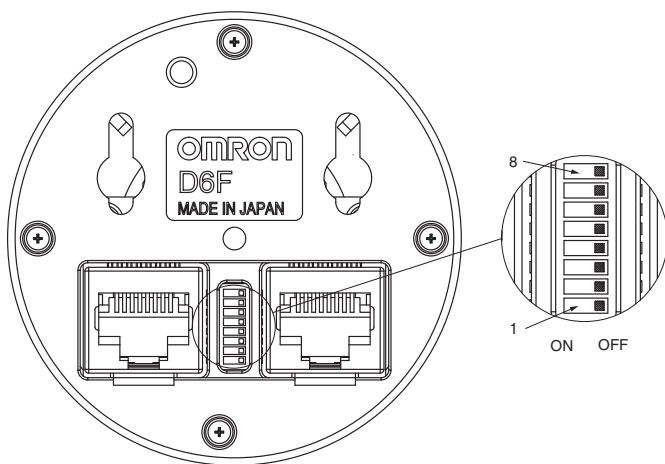

Circuits	Function	ON	OFF
8	Built-in termination resistor	Enable	Disable
7	Baud rate	38400bps	9600bps
6	None	-	-
5	Slave Address : bit 4	1	0
4	Slave Address : bit 3	1	0
3	Slave Address : bit 2	1	0
2	Slave Address : bit 1	1	0
1	Slave Address : bit 0	1	0

Note: Slave address of the device = 1 + (5 bit of integer consisting of circuit number 1 to 5).

D6F-D

MEMS 2-Axis Flow Sensor

Dimensions (Unit: mm)

D6F-D010A32-00

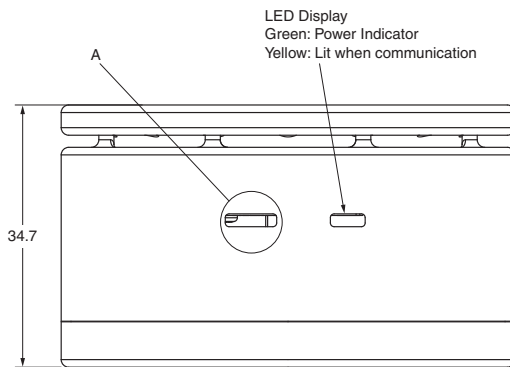
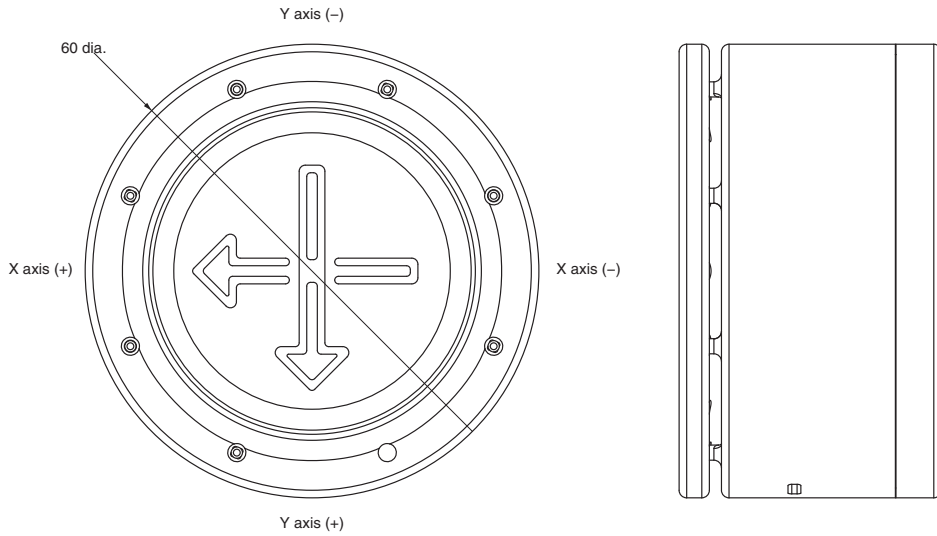

Description A

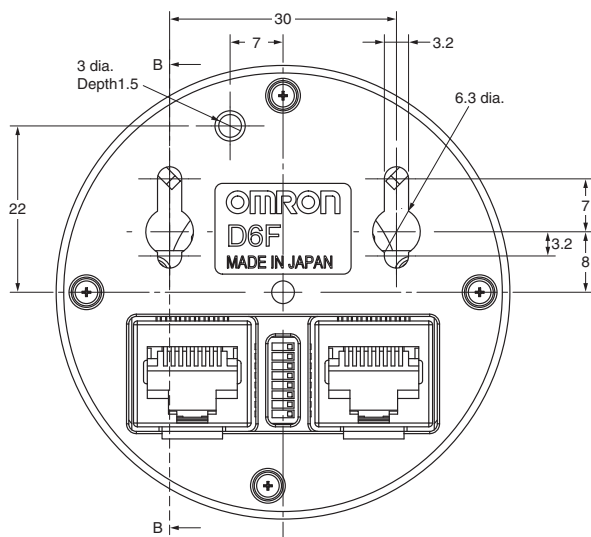
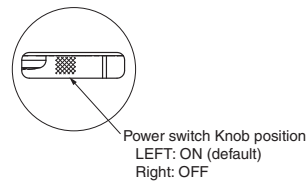

Cross B-B

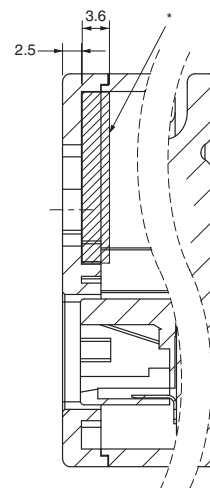

* When using the fixing hole, Please do not exceed the depth (3.6 mm) of the shaded portion.

Application Example

- Air conditioners
- Heating and air conditioning systems
- Alternative for thermal dispersion measurement
- Air & water cooled chillers, indoor packaged AC systems
- Window / split, multi-split residential AC coolers
- Air purifiers, dehumidifiers
- Fan assisted space heaters
- Datacenter cooling and ventilation system
- Clean room down flow monitor

Fig. 4 shows an example of multi-drop connection when connecting three devices on the same bus. In this case, slave address, baud rate and built-in termination resistor of each device must be set properly. For more details of communication settings and protocol, please refer to communication specification (No. MDPE-12-0146).

Fig. 4.

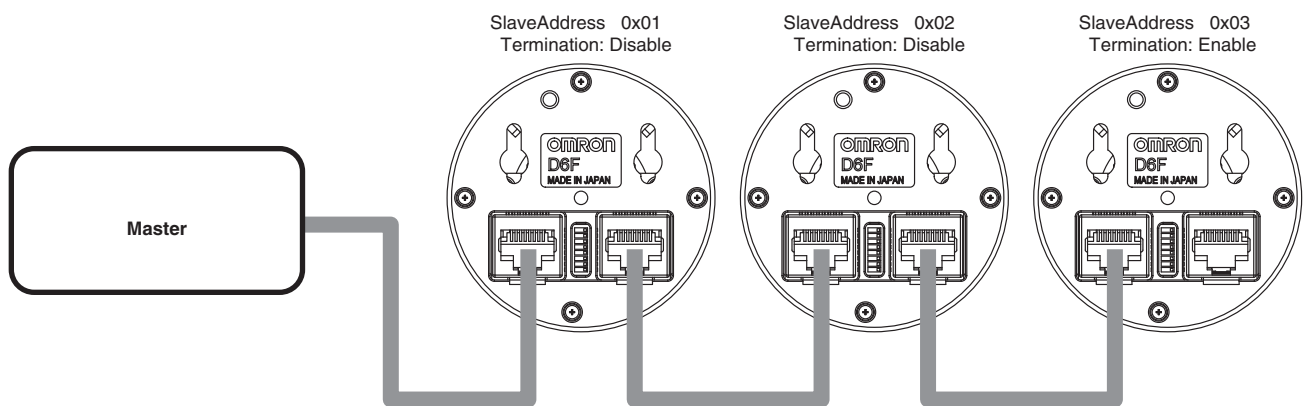

Safety Precautions

CAUTION

- This product is a precision component. Please do not apply shock and external force.
- Please do not use the product that has been dropped from a high distance.
- Please do not modify or disassemble the products in any way.

NOTICE

● Applicable medium and Device mounting

- Depending on the mounting position and the ambient environment, the foreign object such as dust can adhere to the inside of the device and can cause clogging of the part of flow path. As a result, the device may not perform as intended. And, the characteristic specified in this document may not be maintained. Please use the device after enough ex-ante evaluation under the condition of actual use in order to confirm the performance and safety in the application.
- For the gasses other than the applicable medium, please use the device in your responsibility after the confirmation of its performance and safety.
However, do not use in the presence of inflammable gases, such as hydrogen, methane, ethane, and a liquefied petroleum gas. In addition, do not use with corrosive gases (such as chlorine, sulfur, acid, alkali, ammonia etc.)
- The direction of the arrow on top of the body shows the positive direction of the device output in each axis. Please install the device in a correct direction corresponding to the direction of the flow. With the wrong installation, the device cannot measure flow direction correctly.
- After installation, the device may not perform as intended by the presence of a flow obstacle around the device.
- After Installation, the device operation and its performance should be checked before actual use in the application.
- Horizontal device orientation (top cover side up) is recommended. If the device orientation is not horizontal, the output may shift as an offset more than $\pm 3\%$ F.S.. For more details of offset compensation features, please refer to the communication specification.
- The device may not operate properly, if a foreign object or a flow obstacle is placed around the entrance of the flow path.

● Use environment

Please do not use the device in the following environments:

- Places where the device directly receives radiant heat from an apparatus.
- Places where the device is exposed to water, salt water, water droplets and oil splash.
- Places where the device is exposed to direct sunlight.
- Places with volatile gas, inflammable gas or corrosive gas (such as chlorine, sulfur, acid, alkali, ammonia etc.)
- Places where frequent temperature changes.
- Places where dusty condition.
- Places with the possibility of freezing and dew condensation.

- Places where the device receives large magnitudes of vibration and shock.
- Places where the device receives strong electric field effect or magnetic field effect.

● Noise Countermeasures

- Please check electrical noise condition before actual use. The device may not perform as intended by the effect from electrical noise.
- The voltage input that exceeds absolute maximum ratings must not be applied. This can damage the electrical circuit of the device. Place the protection circuit as needed, so that the voltage to the lines will not exceed absolute maximum ratings.
- Take particular care to install away from AC power transformers, live mains power lines and high power magnetic circuits.
- The device may not operate properly where the place with the equipment that generates strong high-frequency wave or surge.
- Please attach surge absorber or noise filter to the peripheral equipment that generates noise.
- In order to prevent inductive noise, wiring of the device must be separated from the power line with the high voltage and large current.
- When using with a switching regulator or DC-DC convertor, switching noise may affect the device operation.

● Handling

- Please handle with countermeasure against static electricity.
- Do not make a direct solder connection to the integral terminals; this may result in damage, and possibly cause failure. It is recommended to use the standard straight CAT5e LAN cable and to ensure correct connection.
- Do not mix up the wiring. This can damage the device and cause the failure.
- Power must be supplied from the single source. And, do not apply different voltage to the device from each connector. This may damage the device and also the host equipment (master).
- After wiring cables, please do not apply excessive pulling force to the connector. Tensile force of 12N or more can cause the failure.
- Changing DIP switch setting must be done when in power off state.

● Communication

- When using the multiple devices on the same bus, please make sure that there is no device that has the same slave address, please refer to the communication specification (No.MDPE-12-0146).
- When using built-in termination resistor, please enable it only to one device at the end of the bus.
- Please make sure that there are no multiple devices with termination resistors enabled.
- Please make sure that baud rate setting must be same for the host equipment (master) on the same bus.

- Application examples provided in this document are for reference only. In actual applications, confirm equipment functions and safety before using the product.
- Consult your OMRON representative before using the product under conditions which are not described in the manual or applying the product to nuclear control systems, railroad systems, aviation systems, vehicles, combustion systems, medical equipment, amusement machines, safety equipment, and other systems or equipment that may have a serious influence on lives and property if used improperly. Make sure that the ratings and performance characteristics of the product provide a margin of safety for the system or equipment, and be sure to provide the system or equipment with double safety mechanisms.