

Manuscript Paper Sensor (1 Beam: 80 mm)

EY3A-1081

⚠ Be sure to read *Precautions* on page 25.

■ Dimensions

Note: All units are in millimeters unless otherwise indicated.

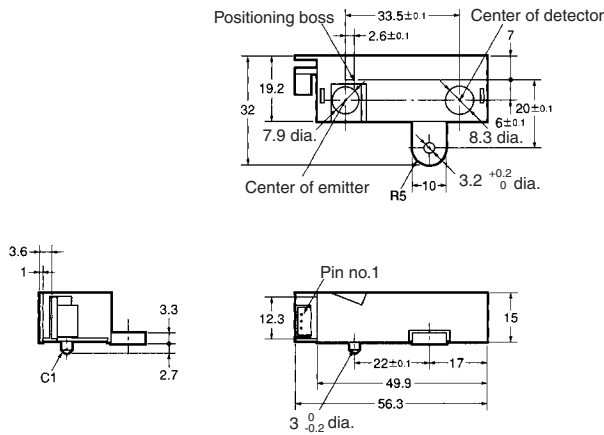

Pin no.	Remarks	Name
1	O	Output (OUT)
2	V	Power supply (Vcc)
3	G	Ground (GND)

Unless otherwise specified, the tolerances are as shown below.

Dimensions	Tolerance
3 mm max.	±0.3
3 < mm ≤ 6	±0.375
6 < mm ≤ 10	±0.45
10 < mm ≤ 18	±0.55
18 < mm ≤ 30	±0.65
30 < mm ≤ 50	±0.8
50 < mm ≤ 80	±0.95

Recommended Mating Connectors:
 Japan Molex 51090-0300 (crimp connector)
 52484-0310 (press-fit connector)

■ Electrical and Optical Characteristics (Ta = 0°C to 60°C)

Item	Value	Condition
Power supply voltage	5 V ±5%	---
Current consumption	50 mA max.	V _{CC} = 5 V, R _L = ∞
Peak current consumption	200 mA max.	V _{CC} = 5 V, R _L = ∞
Low-level output voltage	0.6 V max.	V _{CC} = 5 V, I _{OL} = 4 mA (see note 1)
High-level output voltage	3.5 V min.	V _{CC} = 5 V, R _L = 4.7 kΩ (see note 2)
Response delay time (High to Low)	1.5 ms max.	The time required for the output to become "Lo" after placing sensing object.
Response delay time (Low to high)	1.5 ms max.	The time required for the output to become "Hi" after removing sensing object.

- Note:**
- These conditions are for the sensing of lusterless paper with an OD of 0.7 maximum located at the correct sensing position of the Sensor as shown in the optical path arrangement on page 9.
 - These conditions are for the sensing of the paper supporting plate with an OD of 0.05 located using the glass plate without paper as shown in the optical path arrangement on page 9.

■ Features

- Ensures higher sensitivity and external light interference resistivity than any other photomicrosensor.
- Narrow sensing range ensures stable sensing of a variety of sensing objects.

■ Absolute Maximum Ratings (Ta = 25°C)

Item	Symbol	Rated value
Power supply voltage	V _{CC}	7 V
Load voltage	V _{OUT}	7 V
Load current	I _{OUT}	10 mA
Ambient temperature	Operating	T _{opr} 0°C to 60°C
	Storage	T _{stg} -15°C to 70°C

Note: Make sure there is no icing or condensation when operating the Sensor.

**Characteristics (Paper Table Glass: t = 6 mm max., Transparency Rate: 90% min.)
(Ta = 0°C to 60°C)**

Item	Characteristic value
Sensing density	Lusterless paper with an OD of 0.7 max. (sensing distance: 80 mm) (see note)
Non-sensing distance	120 mm (from the top of the sensor), OD: 0.05
Paper sensing distance	80 mm (from the top of the sensor)
Ambient illumination	Sunlight: 3,000 lx max., fluorescent light: 2,000 lx max.

- Note:** 1. The data shown are initial data.
2. Optical darkness (OD) is defined by the following formula:

$$OD = -\log_{10} \left(\frac{P_{OUT}}{P_{IN}} \right)$$

P_{IN} (mW): Light power incident upon the document
P_{OUT} (mW): Reflected light power from the document

Optical Path Arrangement

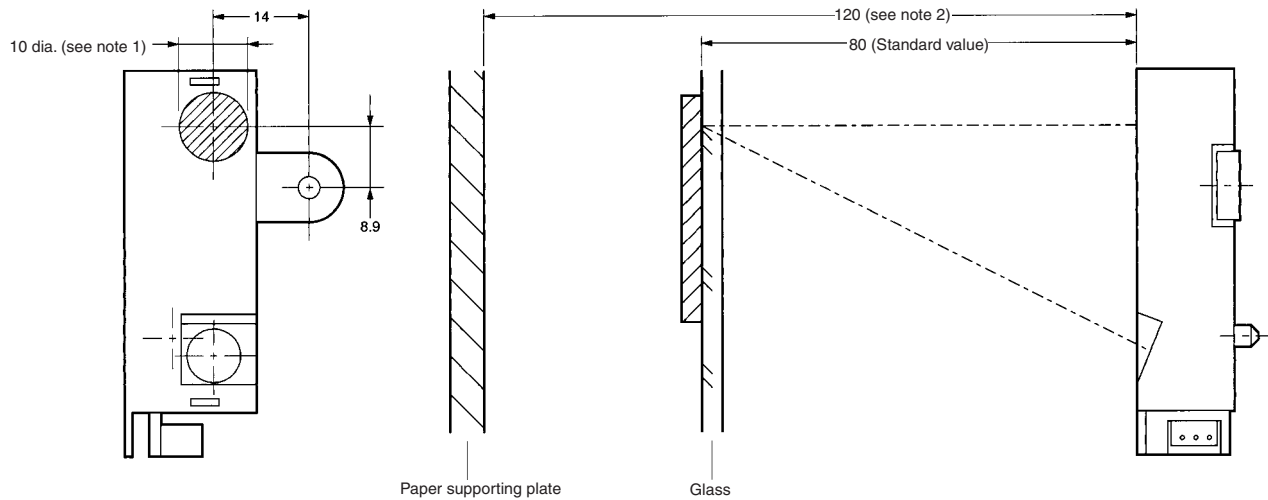

- Note:** 1. The part with oblique lines indicates the paper sensing area of the EY3A-1081, which is practically determined by the diameter of the beam and its tolerance.
2. The non-sensing distance of the EY3A-1081 is determined using a paper with an OD of 0.05.

Engineering Data

Distance Characteristics (Typical)

