



PARA LIGHT ELECTRONICS CO., LTD.

4F, No.1, Lane 93, Chien Yi Road, Chung Ho City, Taipei, Taiwan, R.O.C.

Tel: 886-2-2225-3733

Fax: 886-2-2225-4800

E-mail: para@para.com.tw

<http://www.para.com.tw>

DATA SHEET

PART NO. : EP505L-350IR4

REV : A / 0

CUSTOMER'S APPROVAL : _____

DCC : _____

DRAWING NO. : DS-53-06-0006

DATE : 2006-09-29

Page : 1

● PACKAGE DIMENSIONS

TOP VIEW

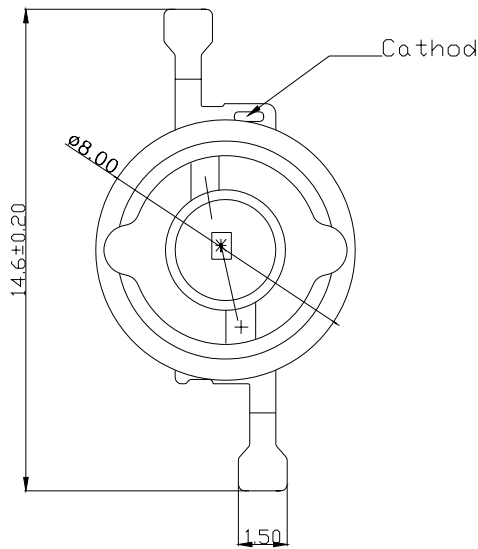

SIDE VIEW

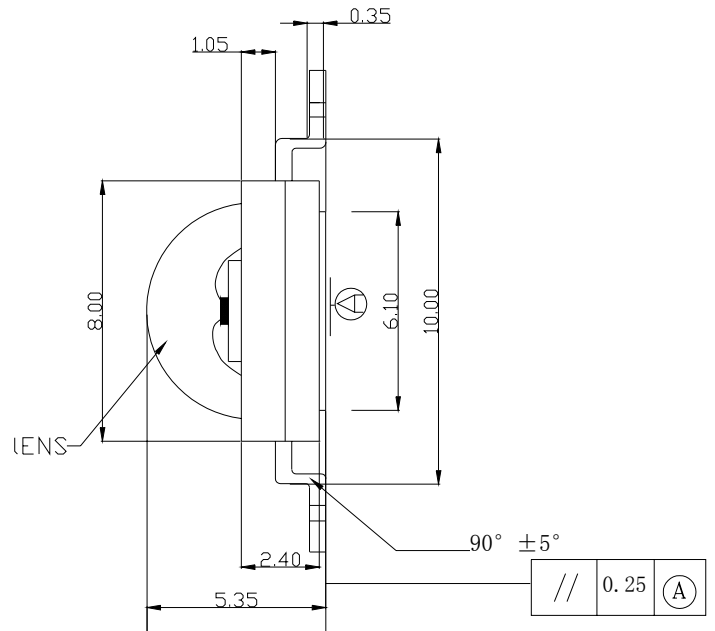

Notes:

1. All dimensions are in millimeters.
2. Tolerance is $\pm 0.25\text{mm}$ (.020") unless otherwise

● Features

- * HIGHEST FLUX PER LED IN THE WORLD
- * VERY LONG OPERATING LIFE
- * MORE ENERGY EFFICIENT THAN INCANDESCENT AND MOST HALOGEN LAMPS
- * LOW VOLTAGE DC OPERATED
- * COOL BEAM SAFE TO THE TOUCH
- * INSTANT LIGHT (LESS THAN 100NS)
- * NO UV

● Chip Materials

- * Dice Material : GaAIAs
- * Light Color : Infrared
- * Lens Color : Water Clear

● Absolute Maximum Ratings(Ta=25°C)

Symbol	Parameter	Rating	Unit
IF	DC Forward Current	350	mA
I _{pulse}	Peak pulse current; (t _p ≤ 100us, Duty cycle=0.25)	500	mA
V _R	Reverse Voltage	5	V
I _r	Reverse Current(V _r =5V)	50	uA
T _j	LED junction Temperature(at 350mA)	125	°C
*Topr	Operating Temperature	-30 ~ +100	°C
*Tstg	Storage Temperature	-40 ~ +100	°C
Tsol	Manual Soldering Time at 260°C(Max.)	5	seconds

Note :

* : Temperature for using with aluminum board.

HBM : Human Body Model. Seller gives no other assurances regarding the ability of to withstand ESD.

● Electro-Optical Characteristics(Ta=25°C)

Parameter	Symbol	Min.	Typ.	Max.	Unit	Test Condition
Luminous Intensity	IV	22.24	46		mw/sr	IF=350mA/100ms
Viewing Angle	2 θ 1/2		130		deg	Note 2
Peak Emission Wavelength	λ _p		850		nm	Measurement @Peak
Spectral Line Half-Width	Δ λ		50		nm	
Forward Voltage	VF	1.55		2.65	V	IF =350mA
Reverse Current	IR			100	μ A	VR = 5V

● Typical Optical and Electrical

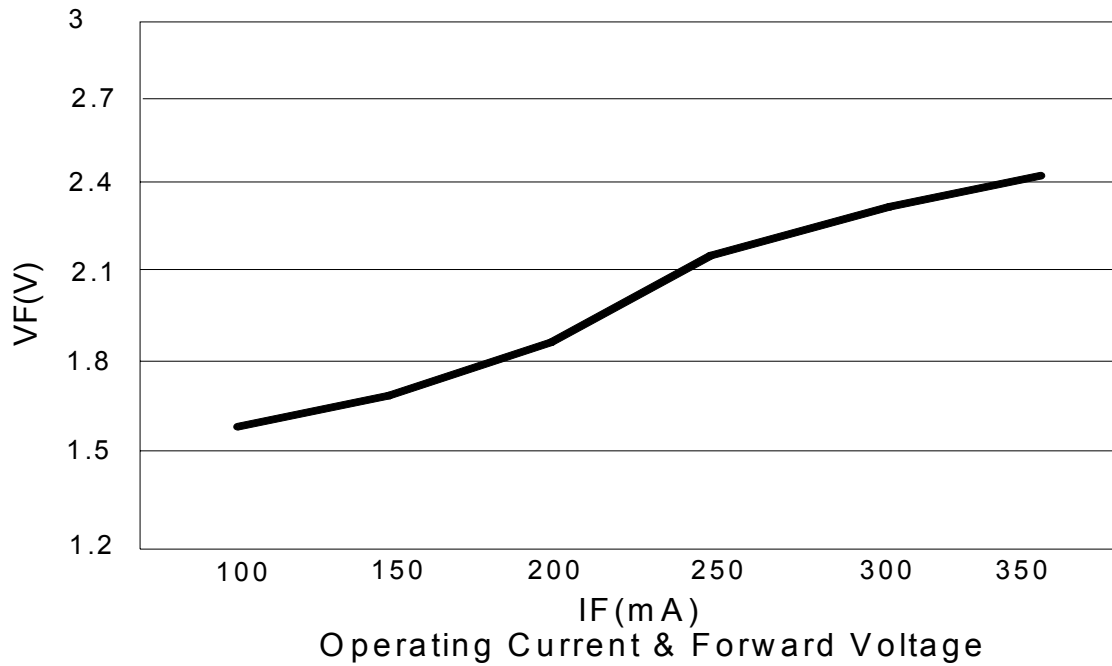
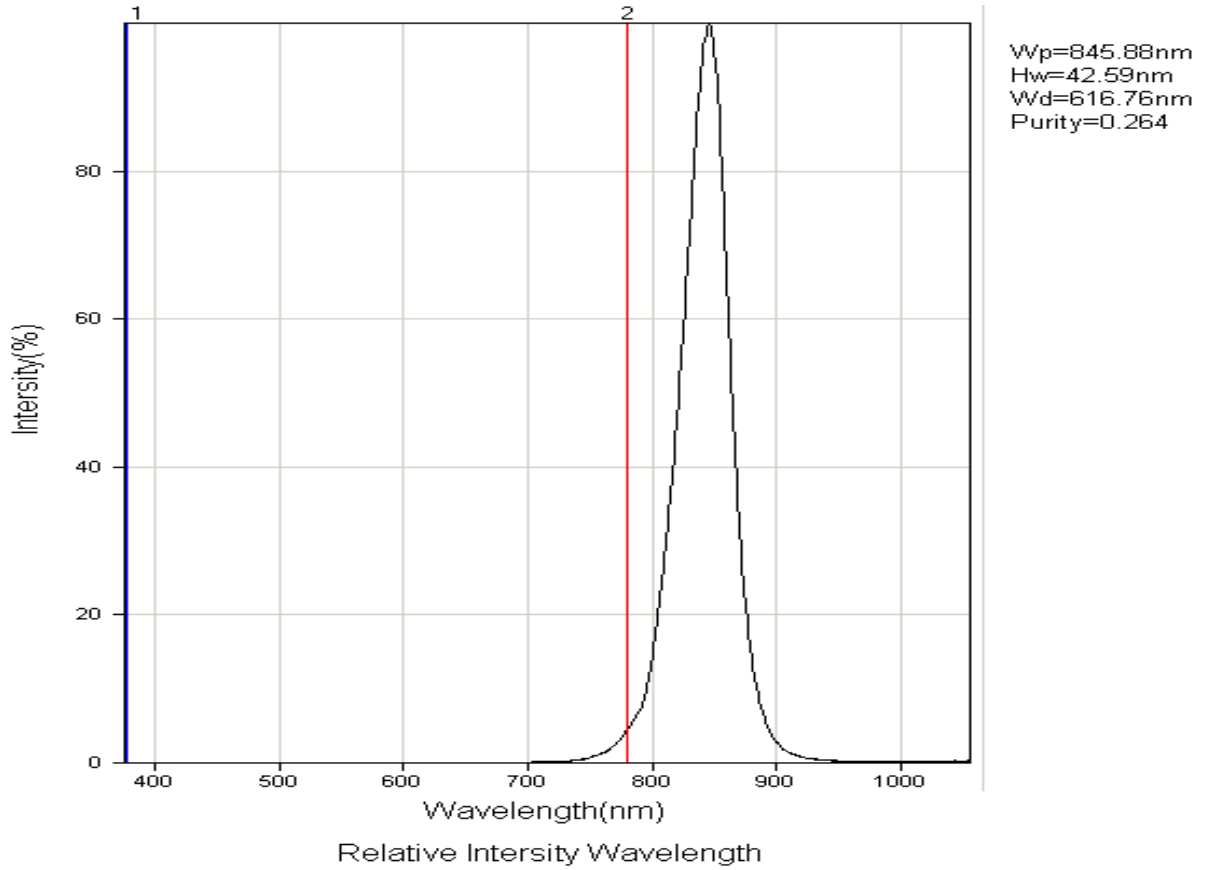

● Typical Optical and Electrical

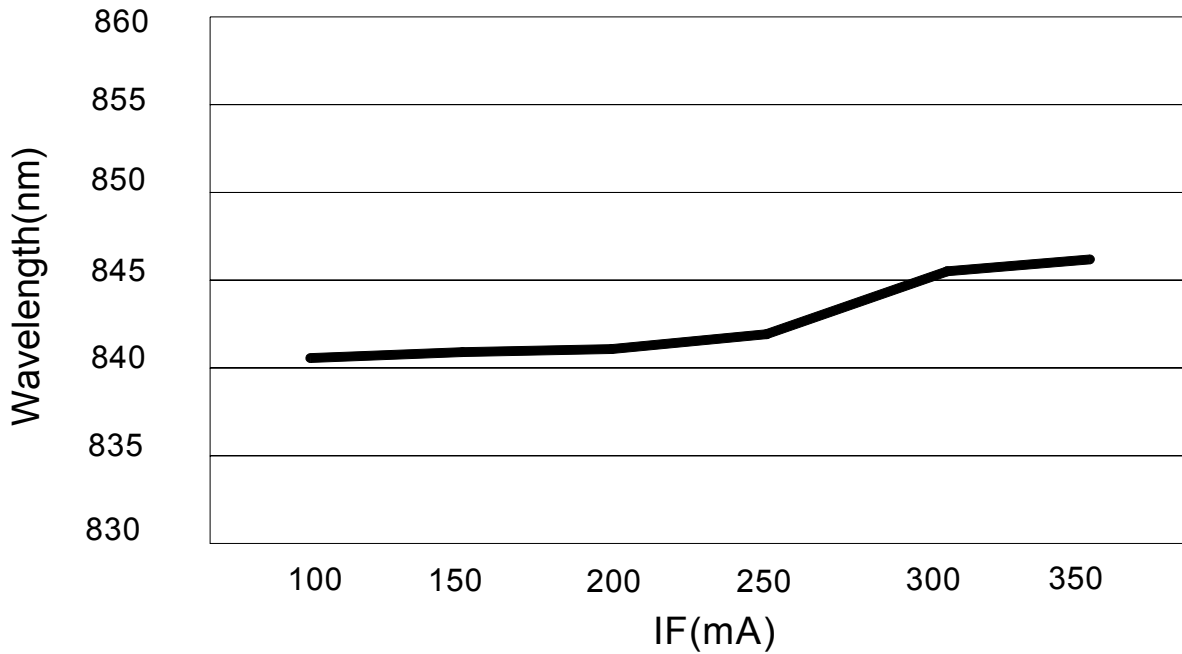

Forward Current & Wavelength

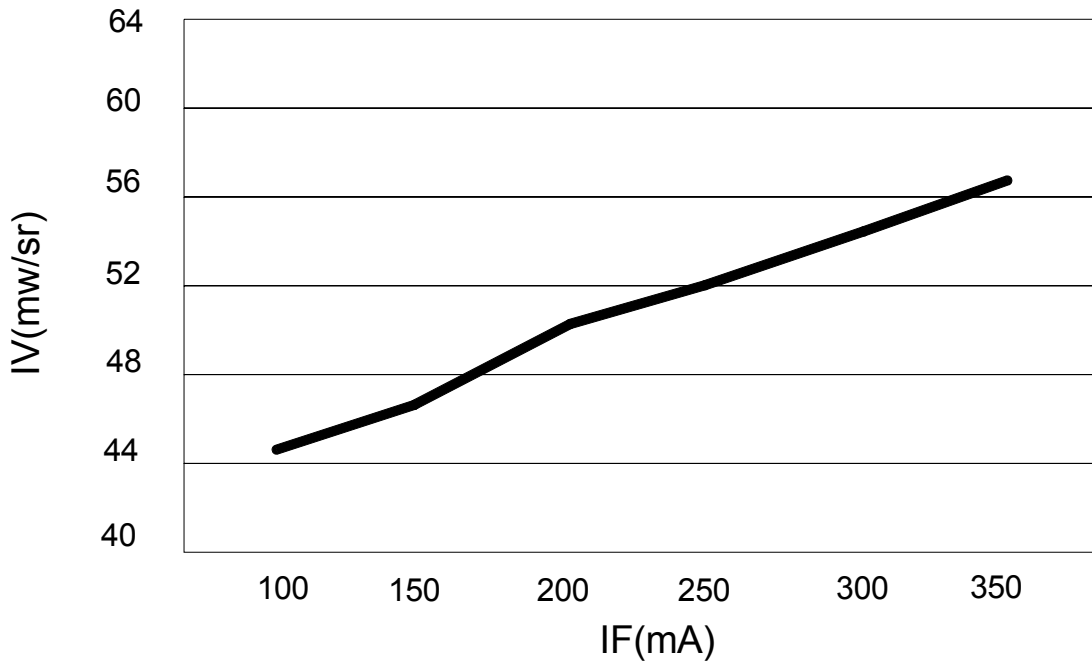

Forward Current & IV

● Typical Optical and Electrical

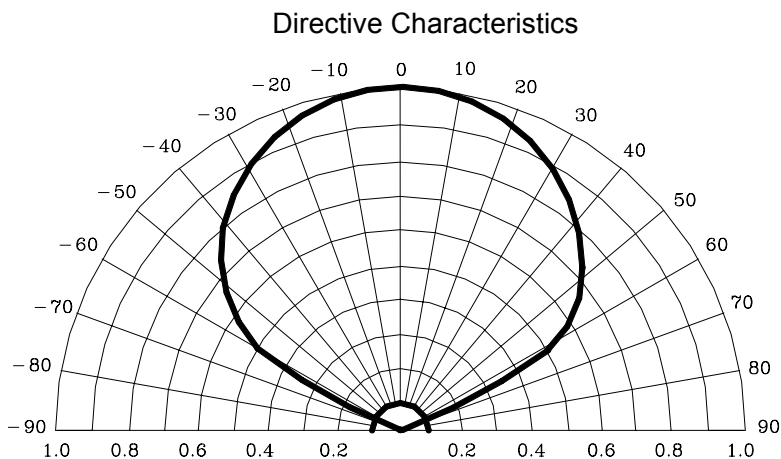

● Operating conditions:

1. 350mA operating condition under f=1K Hz and 1/2 duty cycle.
2. 1000mW : 2pins and Slug independent of E-Power LED must be mounted on PCB.
(PCB : ϕ 19.9mm 1.6t / two layers / 2.0 oz)

● Label Explanation

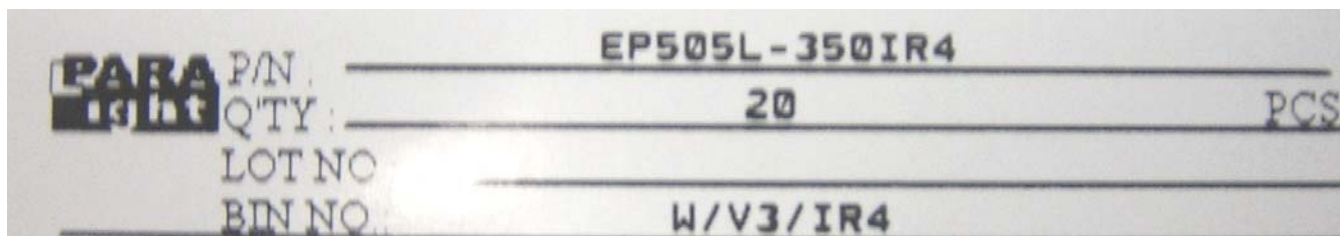

PART NO: EP505L-350IR4

LOT NO: E L E 6 5 0002
 A B C D E F

- A---E: For series number**
- B---L: Local F: Foreign**
- C---E: EPOWER**
- D---Year**
- E---Month**
- F---SPEC.**

BIN NO: BIN CODE

**QUANTITY: (Below are standard specification, actual packing quantity reference page 6)
 70pcs for one tube, 70 tubes in a box(70*70=4900pcs).**

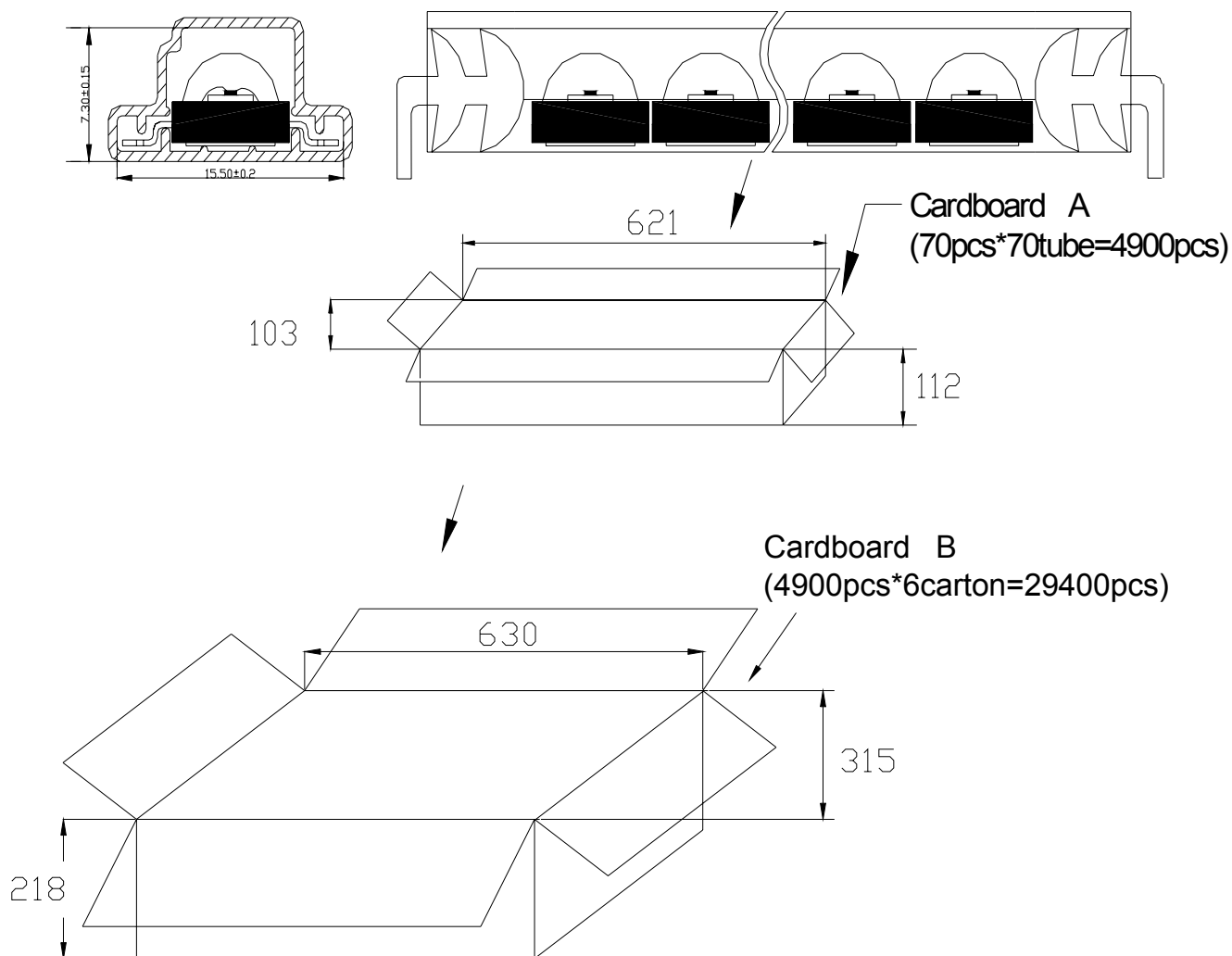
● PACKING SPECIFICATIONS**Notes:**

1. All dimensions are in millimeters.
2. Normal packing Quantity: 4900 pcs.
3. The carton B contains 6 carton A at maximum.

● Suggest Soldering Pad Dimensions

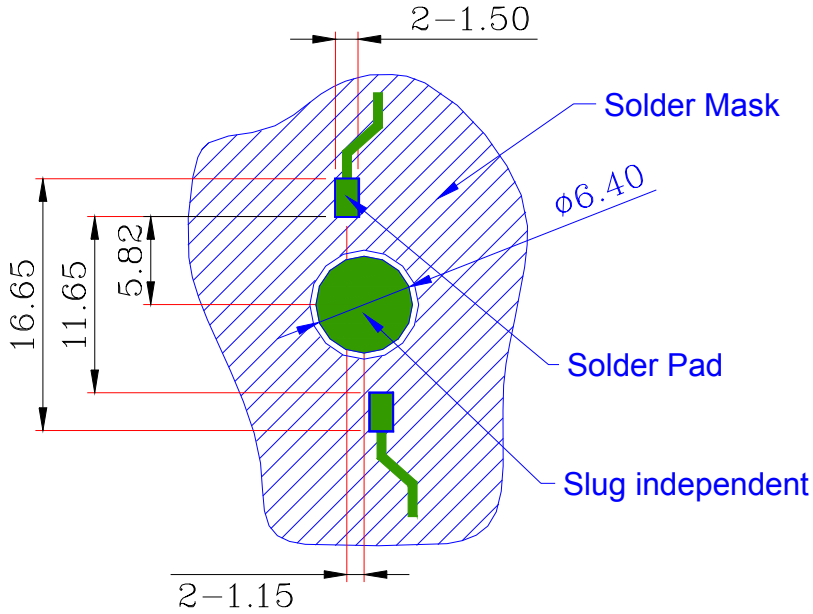

Note:

1. All dimensions are in mm
2. The drawings are not to scale
3. Solder pad can't be connected to slug.

● Bin Code List

Luminous Intensity(IV), Unit:mw/sr@350mA		
Bin Code	Min	Max
V	22.24	35.33
W	29	46
X	38	60
Y	49	78

Forward Voltage(VF), Unit:V@350mA		
Bin Code	Min	Max
V2	1.55	1.85
V3	1.75	2.05
V4	1.95	2.25
V5	2.15	2.45
V6	2.35	2.65

Including test tolerance

Including test tolerance

Dominant Wavelength (Hue),Unit: nm@350mA		
Bin Code	Min	Max
IR4	839	861

Including ± 1nm test tolerance

● CAUTIONS

1. Typical Application

Reading Light / Flashlight / Track Lighting/Under Shelf / Task Lighting
 Emergency Lighting / Traffic Signals/Bollards / Security / Garden Lighting

2. Soldering

Recommend Solder Steps

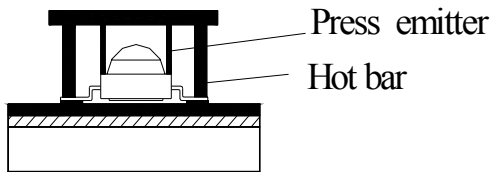

Hot bar soldering

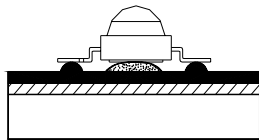

Emitter put on the glue

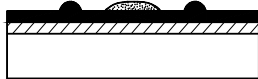

Dispensing Flux

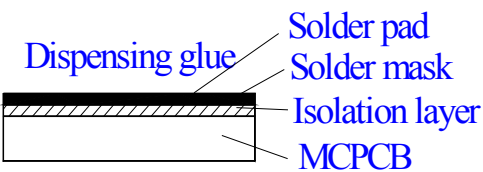
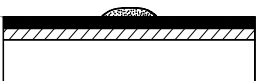

Notes:

1. MCPCB material with a thermal conductivity greater than 2.0 W/mk.
- 2.Solder pad can't be connected to slug.
- 3.The Thermal glue should be as thin as possible for better heat conductivity.
- 4.During any assembly process touching lens is avoided.This will cause pollution or scratch on the surface of lens.

● E-POWER OPERATING PROCEDURE

1. E-power 350 series should be operated at 350 mA for ideal performance, but not more than 360mA.
2. Ep5 can't be soldered with solder paste using reflow process. The suggested soldering temperature in the data sheet.
3. Blue, Cyan, Green and White colors must be used in conjunction with heat-sinking devices. Soldering on Al PCB with mid-connection point while keeping the layout pattern (\varnothing 19.9mm) is another way to help heat dissipation. Thermal Resistance for aluminum board must be less than 0.65 °C/W.
4. Please be aware that the mid-connection point for Red and Amber is negative-polarity while it is non-polarity in Blue, Cyan, Green and White.
5. E-power products are sensitive to static, especially in Blue, Cyan, Green . Operators must wear static wristband (wireless static wristband is prohibited) and be well grounded while working in the environment with an ionizing air blower. Anti-static requirement should be under ESD 400V.
6. E-power products are fully tested and shipped in anti-static packaging.
7. A non-conductive heat-dissipating paste should be applied between E-power and heat-sinking device.
8. It is recommended to design circuit in series with protected IC to limit current flow. In a parallel connection, each IC should be protected individually.

● Reliability Test

Classification	Test Item	Test Condition	Reference Standard	Units Tested	Units Failed
Endurance Test	High Temperature High Humidity Storage 1	In-Board, 1 Times Ta= 85±5°C, RH= 90~95% Current =45mA *Test Time= 1000HRS±2HRS		22	0
	High Temperature High Humidity Storage 2	In-Board, 1 Times Ta= 85±5°C, RH= 90~95% Reverse Voltage=5V *Test Time= 1000HRS±2HRS		22	0
	Life test 1	Ta= 55±5°C Current =70mA *Test Time=1000HRS		22	0
	Life test 2	Ta= -40±5°C Current =70mA *Test Time=1000HRS		22	0
Environmental Test	Temperature Cycling 1	In-Board, 1 Times 100±5°C -55±5°C 15mins DWELL 5nin 20 Cycles 100 Cycles	MIL-STD-883 METHOD 1010	22	0
	Temperature Cycling 2	In-Board, 1 Times 120±5°C -40±5°C 15mins DWELL 5nin 20 Cycles 100 Cycles	MIL-STD-883 METHOD 1010	22	0

● PART NO. SYSTEM OF E-POWER LED

EP 5 05 L – 350IR4– A

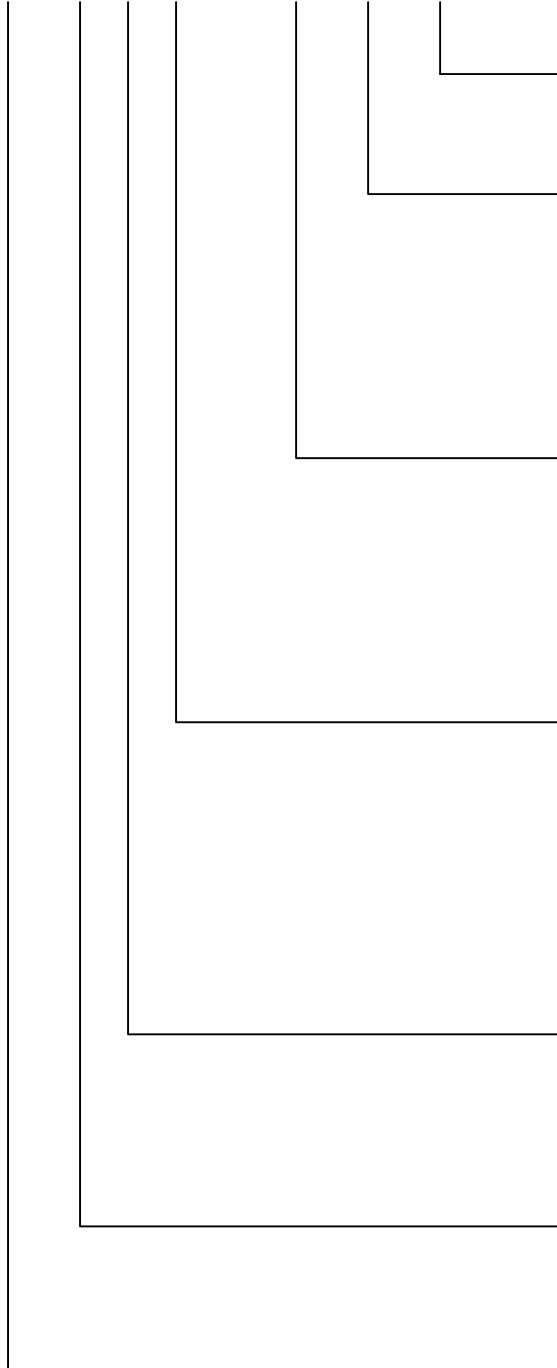

Aluminum Board:
MPST-EVT01-161

λ d:

R1: (Typ) =620nm Y1:(Typ)=595nm
HG1: (Typ) =515nm B1:(Typ)= 460nm
IR4: (Typ) =850nm

CURRENT:

35 : 20mA
150:150mA
350:350mA
700:700mA

VIEWING ANGLE:

2: 2*5=10° L : L*5=130°
3:3*5=15° 6 : 6*5=30°
M: M*5=160°
C : C*5=60°
K : K*5=100°

PACKAGE TYPE:

01:10mm LENS 05: LENS
03:5mm LENS
04:11mm LENS
06: Additional photics LENS

2 : YEAR 2002

4 : YEAR 2004

5: YEAR 2005

EP:E-Power LED