

Application Note

AN-CoolMOS-06

200W SMPS Demonstration Board

Author: Marko Scherf, Ilia Zverev

Published by Infineon Technologies AG
<http://www.infineon.com>

Power Conversion



Never stop thinking

This application note describes the 200W SMPS Demonstration Board with Infineon power products like CoolMOS, OptiMOS, TDA16888, SiC Schottky diode thinQ!, small signal N- & P-channel MOSFETs.

Contains

1	Features / Parameters.....	3
2	General Description / Main Function	4
3	Construction / Heatsinks	4
4	Description of Functional Part Groups.....	5
4.1	Power Stages (“Main Board”).....	5
4.1.1	AC input/ EMI Filter	5
4.1.2	PFC Converter	5
4.1.3	PWM Converter (Two Transistor Forward).....	6
4.1.4	Synchronous Rectification	6
4.2	Controlling Circuitry (“Control Board”)	6
4.2.1	General Description of the Combi-IC TDA16888.....	7
4.2.2	PFC Control.....	7
4.2.3	PWM Control	7
4.2.4	Gate Drive Circuitry	7
5	Power Losses / Efficiency	8
6	Power Loss Sources	9
7	Conducted EMI Measurements	10
8	Construction of magnetic components	12
8.1	PFC choke.....	12
8.2	Main transformer	13
8.3	Output filter choke	14
9	PCB Layout	15
9.1	Main Board - Scaling 1:1	15
9.2	Control Board- Scaling 1:1	18
10	Bill of Materials.....	18
10.1	Main Board.....	18
10.2	Control Board.....	21

1 Features / Parameters

Features:

- Infineon & EPCOS components on board
- Second generation of CoolMOS C2 as PFC, PWM switches
- Silicon Carbide (SiC) Schottky diode thinQ! as PFC diode
- OptiMOS as synchronous rectification switches
- PFC and PWM controller in one IC
- High efficiency
- No external heat sink required
- No minimum output load required
- Output over load protected
- Output short circuit protected

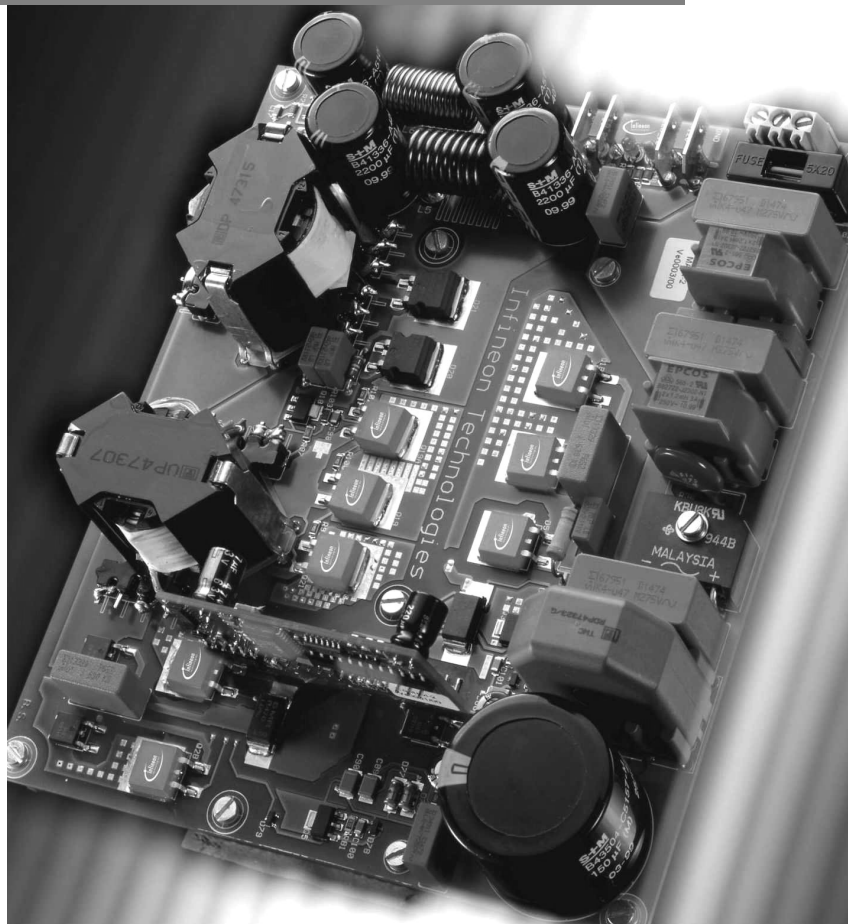

Parameters:

- wide input voltage range 90-275V
- output power 200W
- output voltages
- 5V / 20A max (load resistance = 0.25Ohm)
- 12V / 8.3A max (load resistance = 1.45Ohm)
- active Power Factor Correction boost converter operates at 200kHz
- hard switching two transistor forward converter operates at 200kHz
- synchronous rectification for 5V output operates at 200kHz

2 General Description / Main Function

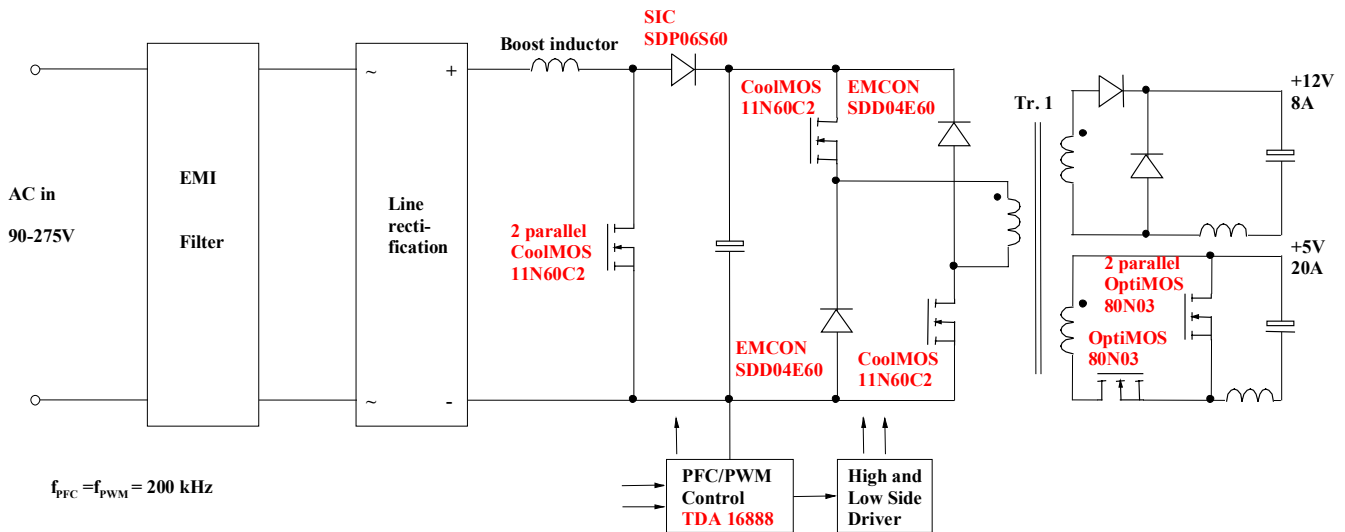

Block Diagram

The SMPS Demoboard consists of two power stages, a AC-DC- converter for power factor correction (PFC section) and a PWM-controlled DC-DC-converter configured as a two-transistor forward topology (PWM section). The PFC stage is a step up (boost) converter which serves to provide a 380V DC-bus at its output while consuming sinusoidal line current (near a unity power factor) at the input. Another PFC related feature is the ability to supply the converter with a wide range input voltage (90-275 VAC) without range switches to re-configure the rectifier assembly. The power semiconductors used are two CoolMOS SPB11N60C2 in parallel and a silicon carbide diode prototype SDB06S60 (6A/600V).

The two-transistor forward-converter provides isolation from the AC line. There are two output voltages, 5VDC and 12VDC. At the primary side the power semiconductors are two CoolMOS SPB11N60C2 and two EMCON diodes prototypes SDD04E60 (4A/600V). At the secondary side the rectification principle is different for each output. At the 12V-path there is a conventional rectification with Schottky diodes. The 5V output is realized as synchronous rectification using low voltage MOSFETS SPB80N03S2L-03.

One single integrated circuit, a TDA16888, provides control for both power stages, the PFC and PWM sections.

3 Construction / Heatsinks

A larger PCB (called “main board”) is the mechanical base of the SMPS. It carries the power semiconductors (in SMD lead frame technology) and the passive devices of the power stages. No additional heatsink is used. The copper layers of the board serve to distribute the dissipated energy with the help of a metal plate at the bottom of the board. A smaller PCB (called “control board”) carries the controlling circuitry and is plugged to the “main board” at its top.

4 Description of Functional Part Groups

4.1 Power Stages (“Main Board”)

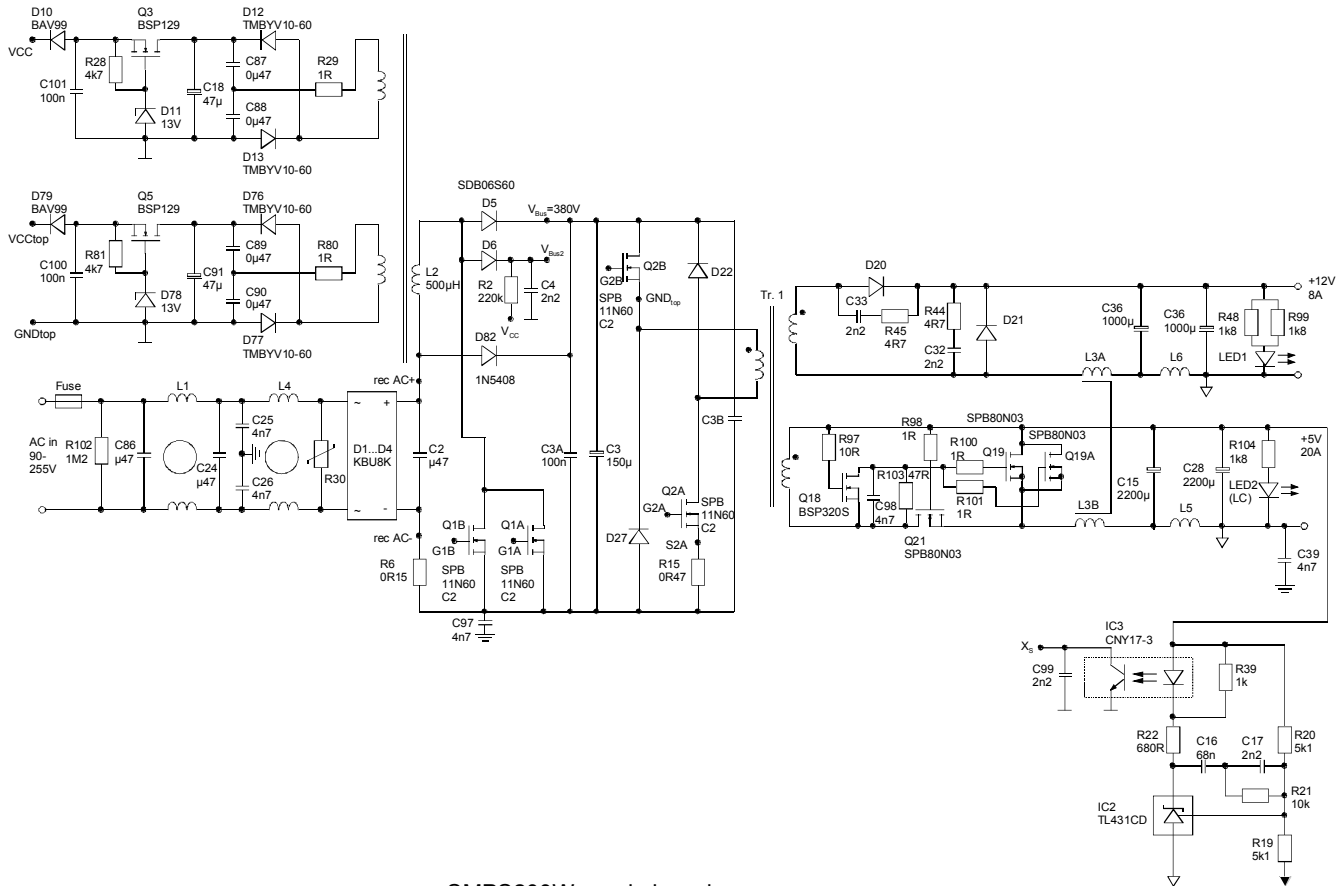

SMPS200W - main board

4.1.1 AC input/ EMI Filter

The input voltage of the SMPS is 90 to 275Vac (50/60Hz). A **Fuse** prevents greater damage in the case of catastrophic failure. The function of the line EMI Filter (**C86, L1, L4, C24...26, C2**) is to suppress the high frequency noise caused by the switching transitions of both power stages. Varistor **R30** serves to suppress high voltage line transients to protect the input. The line rectifier (**D1...4**) consists of standard silicon diodes.

4.1.2 PFC Converter

The PFC converter is a step up topology with continuous inductor current at full load. The switching frequency is 200kHz. The output voltage is approximately 380Vdc. Main parts of the PFC are the boost inductor **L2**, switches **Q1A/Q1B**, boost diode **D5** and the bulk capacitor **C3**. **L2** is an iron powder toroidal core with a single layer of copper wire to keep stray capacitance small. **Q1A/Q1B** are CoolMOS SPB11N60C2 because of their high switching speed and their very low on-resistance (important at low input voltages → higher current, duty cycle). The only reason for paralleling is to get larger cooling areas for better heat distribution at the PCB. The boost diode is a 600V silicon carbide Schottky prototype diode, which has an excellent switching characteristic (no charge storage). **D82**, a conventional silicon diode, is used to initially charge the bulk capacitor from the rectified AC voltage, avoiding high surge current in the unipolar SiC diode. The bulk capacitor **C3** serves to store energy to reduce the second harmonic voltage ripple and it must carry the switching frequency current. **C3A** keeps the commutation circuit short, it's a bypass for high frequency currents.

4.1.3 PWM Converter (Two Transistor Forward)

The PWM converter is a two transistor forward topology. The operating frequency of 200 kHz is same as at the PFC section. Main parts at the primary side are **Q2A/Q2B** and **D22/D27**. When the forward transistors **Q2A/Q2B** are switched on simultaneously, energy is transferred to the output through the transformer. The transistors are chosen as CoolMOS SPB11N60C2 because of their high switching speed. **D22/D27** are EMCON prototype diodes. They serve to clamp the flyback voltages from the transformer leakage inductance, during reset of the transformer magnetization, in every turn off cycle. The transformer **Tr.1** provides galvanic isolation of the output from the line and adapts the output voltages from the voltage of the bulk capacitor. The transformer consists of a RM14/N87-core by EPCOS with litz-windings at the primary and tape windings at the secondary. The windings are interleaved to reduce leakage inductance. Main parts at the secondary are **D20/D21**, **L3A**, **L6** and **C36/C37** (12V-path) and **Q19/Q21**, **L3B**, **L5** and **C15**, **C28** (5V-path). **D20/D21** are 45-volts standard Schottky diodes, which handle the current in both sequences, when the transistors are on in series rectifier mode or as freewheeling path if the transistors are off.

4.1.4 Synchronous Rectification

At the 5V-path there is used a synchronous rectifier with 30V-MOSFETs SPB80N03S2L-03. It uses control waveforms generated by the secondary side of the transformer. Two MOSFETs in parallel, **Q19** and **Q19A** handle the freewheeling current in the "low" PWM state, and one MOSFET, **Q21**, handles the series rectifier circuitry. The freewheeling synchronous rectifiers are turned on in the absence of the PWM pulse output, driven through the body diode of **Q18** during the primary transformer reset interval. When the primary switches turn on, the gate of **Q18** (previously biased negative), driven through **R97** connected to the dot transformer winding, starts switching positive.

4.2 Controlling Circuitry ("Control Board")

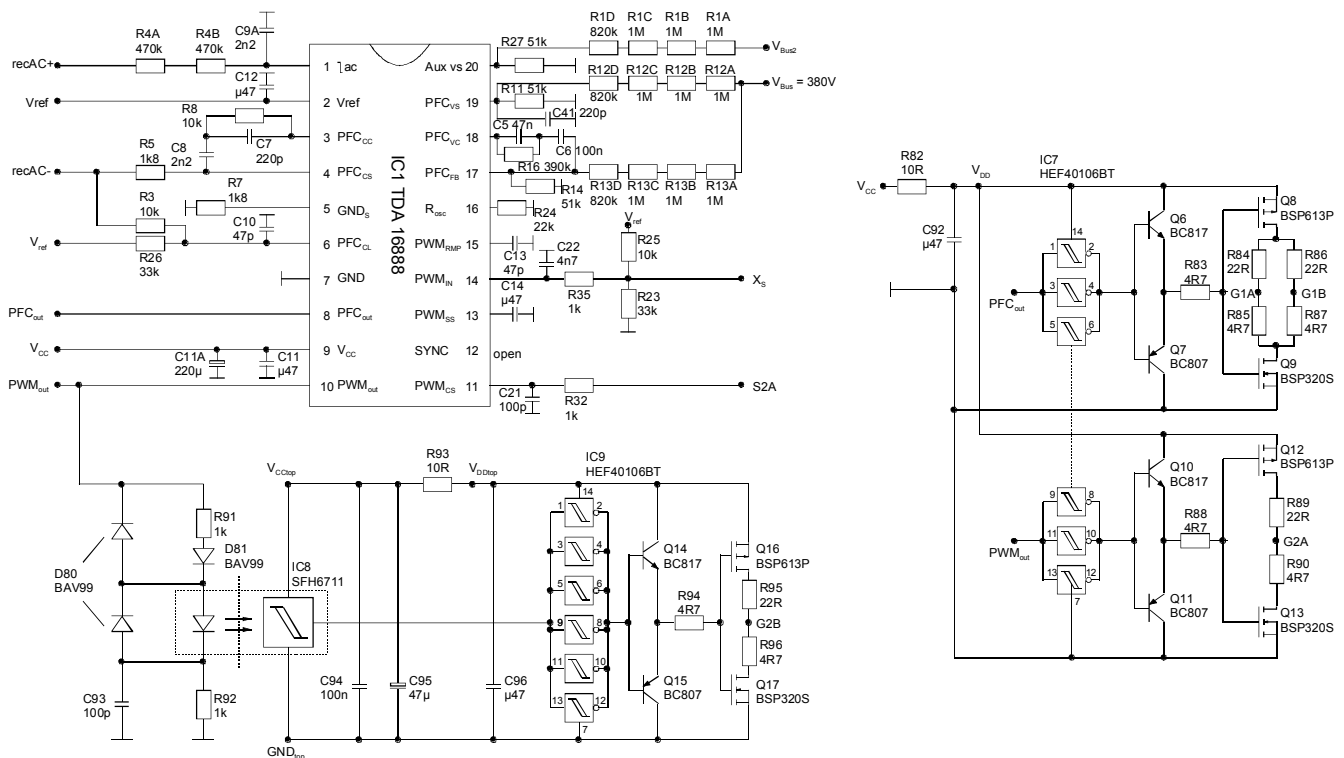

SMPS 200W - control board

4.2.1 General Description of the Combi-IC TDA16888

The TDA 16888 comprises the complete control for power factor controlled switched mode power supplies. With its PFC and PWM section being internally synchronized, it is suitable for two stage off-line converters with worldwide input voltage range. It is designed to reduce system costs by less external parts count.

Special PFC features include:

- Dual loop control (average current and voltage sensing)
- Additional operation mode as auxiliary power supply
- Fast, soft switching totem pole gate drive (1A)
- Leading edge pulse width modulation
- Peak current limitation
- Overvoltage protection

Special PWM features include:

- Improved current mode control
- Fast, soft switching totem pole gate drive (1A)
- Soft-start management
- Trailing edge pulse width modulation
- 50% maximum duty cycle to prevent transformer saturation

4.2.2 PFC Control

The TDA 16888 provides active power factor control in average current control mode. The “heart” of the PFC section is an analog multiplier. It creates the current programming signal for the current amplifier OP2 by multiplying the rectified line voltage with the output of the voltage amplifier so that the current programming signal has the shape of the input voltage and an average amplitude which controls the output voltage. At the Demoboard the external circuitry of the voltage amplifier (voltage sensing, compensating) consists of **R13**, **R14**, **R16**, **C5**, and **C6**. The resistor **R4** serves to monitor the actual rectified line voltage. **R5**, **R7**, **R8**, **C7**, and **C8** are the components belonging to the current amplifier, the inductor current is monitored as a voltage drop at **R6** (located at “main board”). **R3**, **R26** determine the PFC current limit (approx. 6,5A). **R11**, **R12** fix the overvoltage thresholds.

4.2.3 PWM Control

The TDA 16888 provides an improved current mode control containing effective slope compensation as well as enhanced spike suppression. The converter primary side switch current is monitored as voltage drop at **R15** (located at “main board”). The amplified and “cleaned” current signal sensed at PWMCS (11), measurable at PWMRMP (15), together with the output voltage control loop feedback signal at PWMIN (14), are both inputs of the PWM comparator C8. Together they determine the actual duty cycle. **C14** provides soft start of the PWM section. The components of the output voltage control loop are located at the secondary side of the converter (on the “main board”). The feedback signal is transferred across the isolation barrier via a low cost optocoupler, **IC3**.

4.2.4 Gate Drive Circuitry

Because of the very high operating frequency the PFC section power transistors (**Q1A**, **Q1B**) and the low side power transistor (**Q2A**) of the PWM stage are driven by discrete high speed, high current driver stages using small signal bipolar transistors and MOSFETs. That’s why the original gate drive signals at PFCOUT/ PWMOUT are schmitt-triggered and used as inputs of the discrete drivers. The gate drive signal of the high side power transistor (**Q2B**) is transferred via a high-speed optocoupler, **IC8** (SFH 6711), and amplified as described before. The floating supply voltage for the high side driver circuitry is generated by a separate winding of the PFC choke **L2**.

5 Power Losses / Efficiency

Measured power losses at nearly full load and different input voltages:

Vinac/V	Pin/W	Pout/W	V12v/V	I12v/A	V5v/V	I5v/A	η /%
90	224	180,5	10,24	8,56	4,85	19,15	80,6
110	220	180,6	10,25	8,56	4,85	19,15	82,1
150	215	180,8	10,25	8,57	4,85	19,16	84,1
200	215	181,5	10,25	8,65	4,85	19,14	84,4
230	215	181,4	10,24	8,65	4,85	19,14	84,4
275	212	181,4	10,24	8,65	4,85	19,14	85,6

The best efficiency appears at the highest input voltage, the worst at the lowest. The reason is the variation of the line current. Higher input currents result in increased conduction losses at the input rectifier, EMI Filter, PFC choke and PFC current sense resistor. The RMS value of the PFC transistor current is much higher at low line conditions, when the switches have to carry higher peak currents. Furthermore, the transistors switch at twice the effective duty cycle in order to provide a higher step up rate for the PFC stage. The higher current values also cause increased switching losses of the PFC stage. The behavior of the PWM stage doesn't depend on the input voltage, due to the pre-regulated bulk bus from the output of the PFC stage.

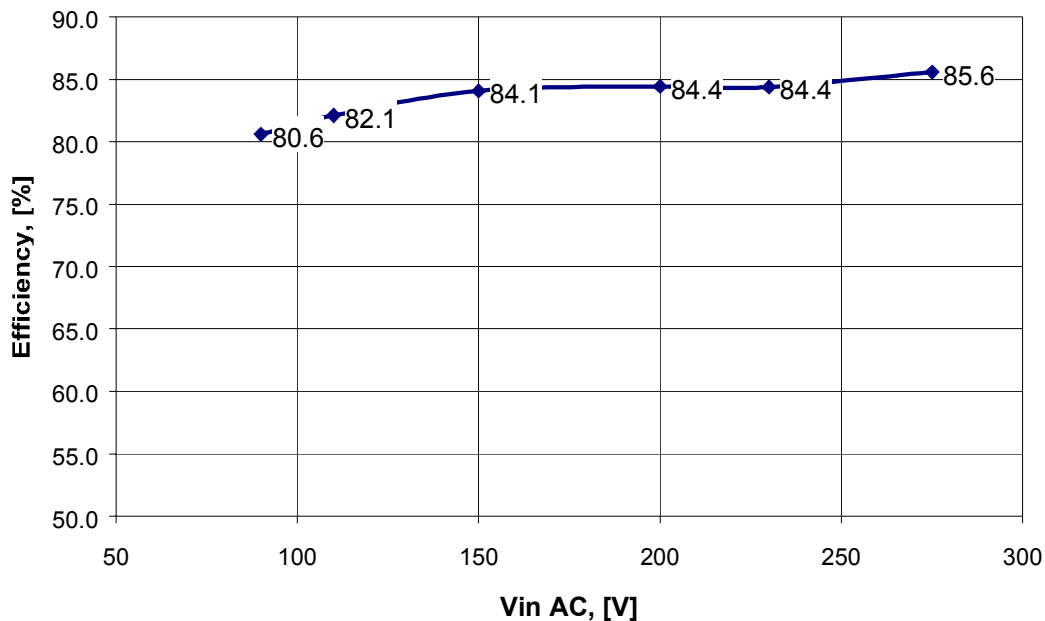

6 Power Loss Sources

The highest power dissipation appears at full load and low line condition.

Operation point:

V_{in} AC = 90V

P_{in} = 224W

P_{out} = 180,5W

⇒ P_{loss} = 43.5W

The distribution of the power losses is calculated or assumed by the help of measured device temperatures.

Power Loss Sources	Assumed Power Dissipation/ W
EMI Filter	1
Line Rectifier (D1...4)	3.5
PFC Choke L2	3
Bulk Capacitor C3	1.5
PFC Transistors Q1	5
PFC Diode D5	1.5
Forward Transistors Q2	2
Transformer Tr.1	5
5V Rectifiers Q19, Q21	3
12V Rectifiers D20, D21	4
Output Choke L3	5
Output Capacitors C36, C37, C15, C28	2
Controlling, Driver, Supply Circuitry	3
Others	4
Σ	43.5

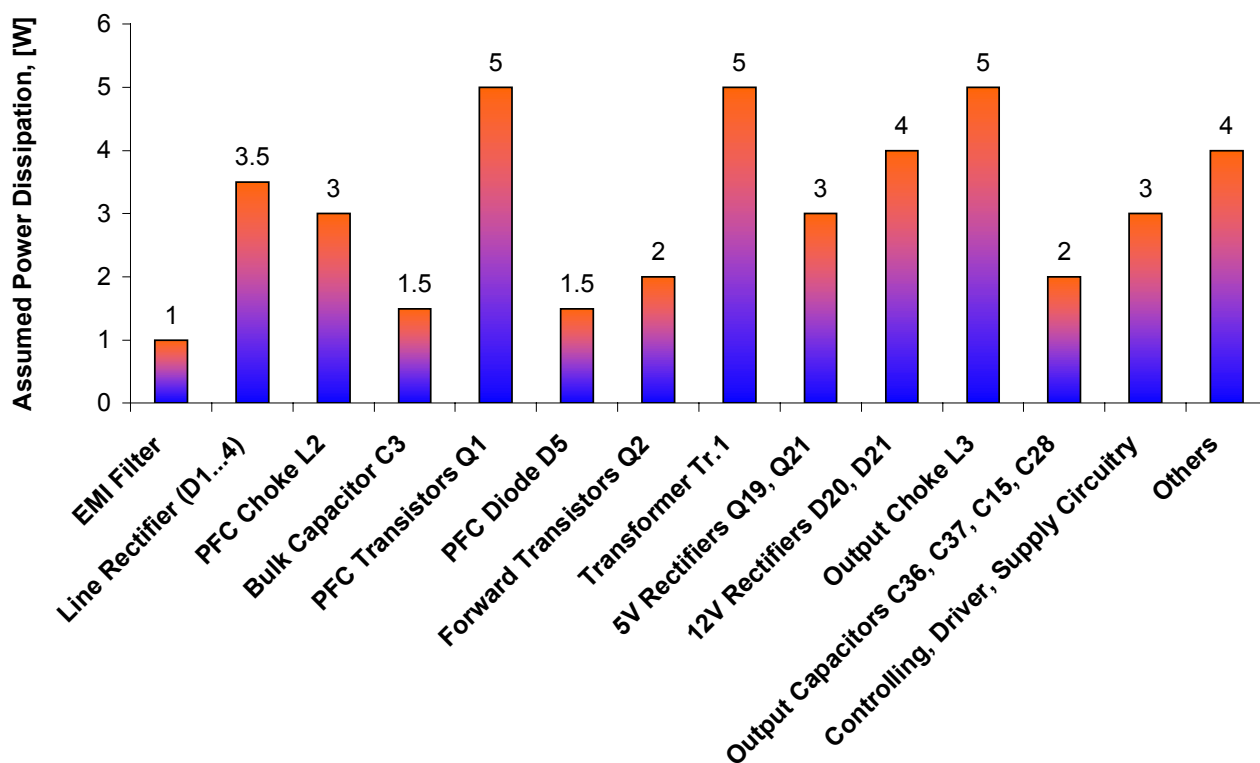

7 Conducted EMI Measurements

Measuring of conducted noise with an EMI-Receiver FMLK 1518 at a Line-Impedance Stabilization Network (LISN) NSLK 8128.

Conditions: VAC in = 230V, Pout = 181,4W, main board in a metal case.

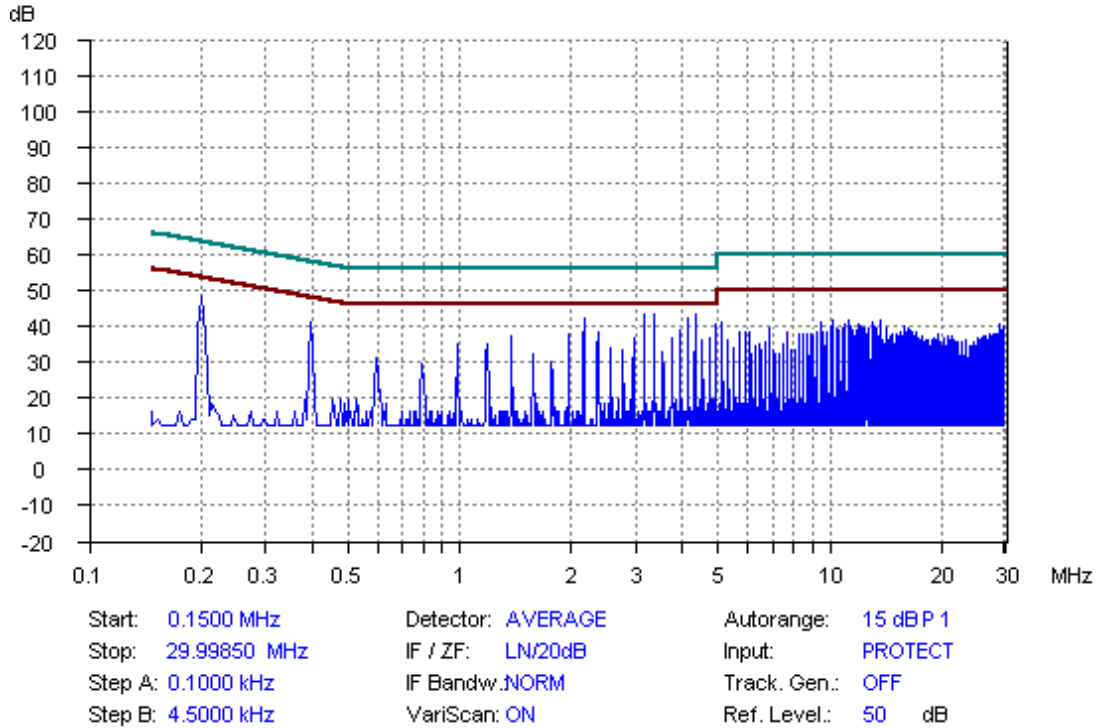

Phase 1, Average

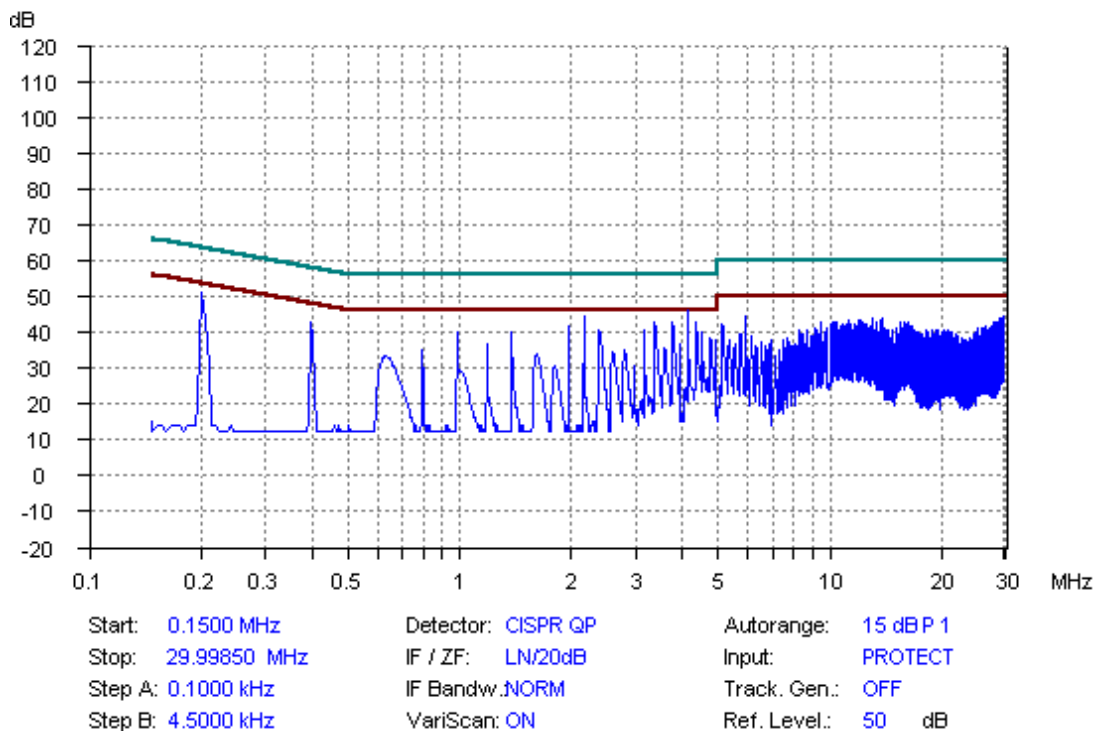

Phase 1, CISPR QP

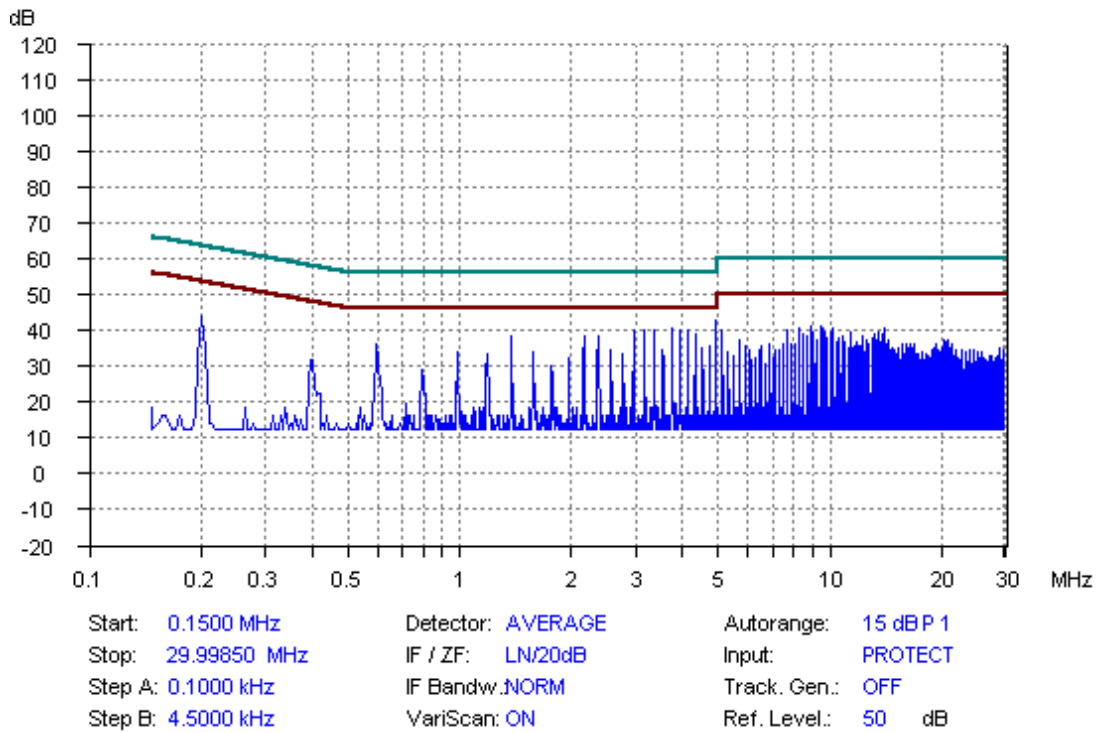

Phase 2, Average

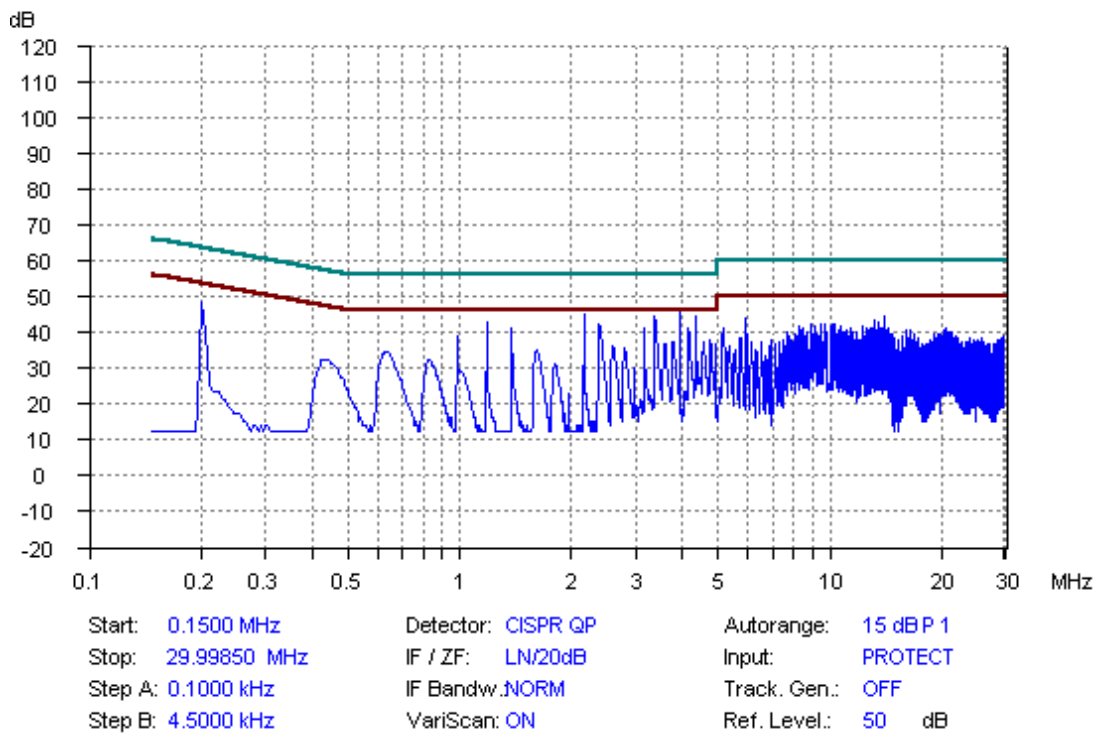

Phase 2, CISPR QP

As it can be seen from the figures above the measured EMI spectra are below the norm limit lines.

8 Construction of magnetic components

8.1 PFC choke

Core: MAGNETICS Ringcore 77930 - A7; L = 490 μ H (Pin1 - Pin8)

1.060"OD \times 0.580"ID \times 0.440"HT (26.9mm \times 14.7mm \times 11.2mm)

Part Number	Perm. (μ)	AL \pm 8%
77932-A7	26	32
77894-A7	60	75
77935-A7	75	94
77934-A7	90	113
77930-A7	125	157

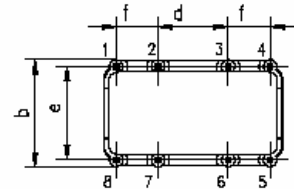
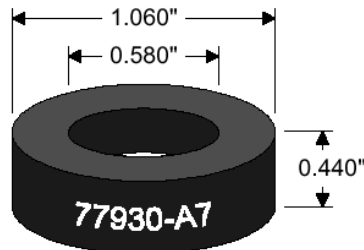

Physical Characteristics		
Window Area	308,000 c.mils	1.56 cm ²
Cross Section	0.1014 in ²	0.654 cm ²
Path Length	2.50 in.	6.35 cm.
Volume	0.254 in ³	4.15 cm ³
Weight	0.056 lb.	25.5 gm.
Area Product	0.0245 in ⁴	1.020 cm ⁴

Core Dimensions (after finish)		
O.D. (max.)	1.090 in.	27.7 mm.
I.D. (min.)	0.555 in.	14.10 mm.
HT. (max.)	0.470 in.	11.94 mm.
Surface Area	3.83 in ²	24.7 cm ²

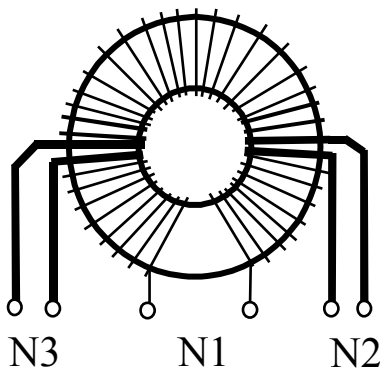
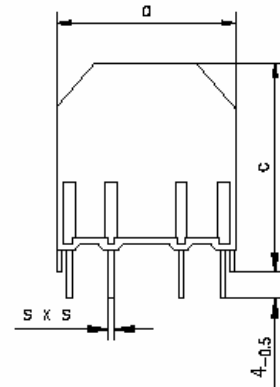

N1: 56 turns 0,5mm \varnothing
 N2: 4 turns 0,2mm \varnothing
 N3: 4 turns 0,2mm \varnothing

Hole arrangement
View in mounting direction

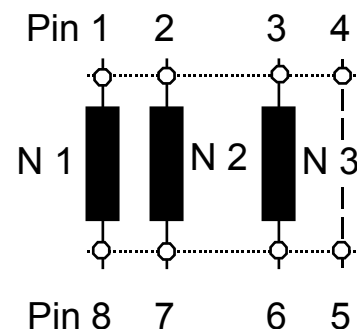

8.2 Main transformer

Core: EPCOS RM 14; N87; without gap; $A_L = 6000 \text{ nH}$;
 $L = 3,0 \text{ mH}$ (Pin1 - Pin6 ; Pin3 connected with Pin4)

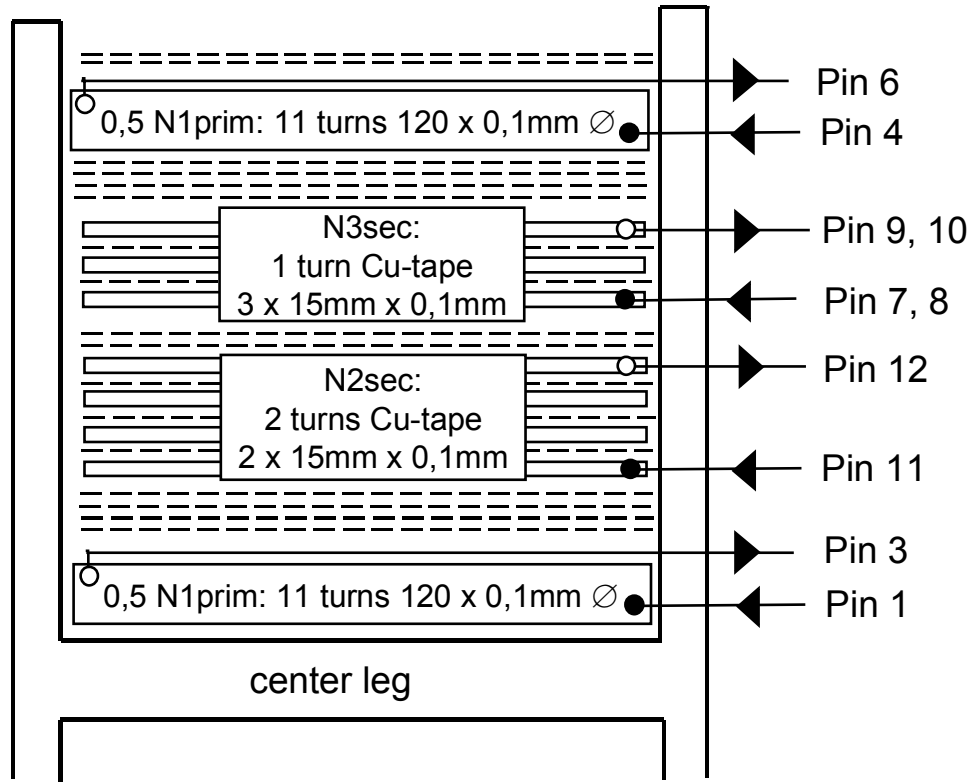

----- 1 layer Makrofol

N1prim: 22 turns 120 x 0,1 \varnothing stranded wire
 N2sec : 2 turns Cu-tape 2 x 15mm x 0,1mm
 N3sec : 1 turn Cu-tape 3 x 15mm x 0,1mm

Hole arrangement
 View in mounting direction

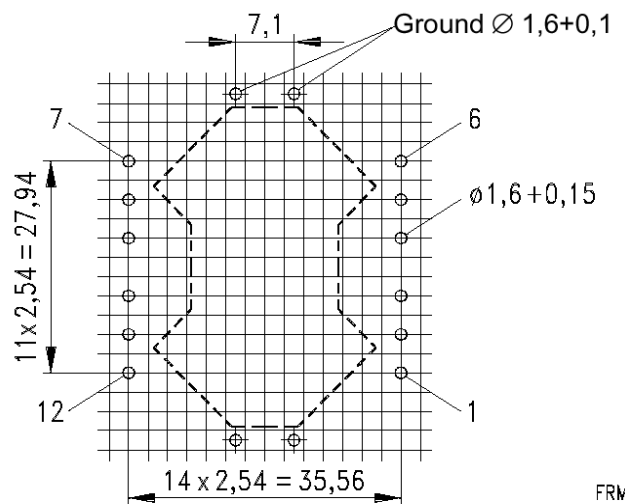

FRM

8.3 Output filter choke

Core: EPCOS RM 14; N41; total gap = 1mm; $A_L = 250 \text{ nH}$;
 $L = 36 \text{ } \mu\text{H}$ (Pin1 - Pin6);
 $(20\text{A} \cdot 5\text{turns} + 10\text{A} \cdot 12\text{turns}) \cdot 250\text{nH} / 170\text{mm}^2 = 320\text{mT}$

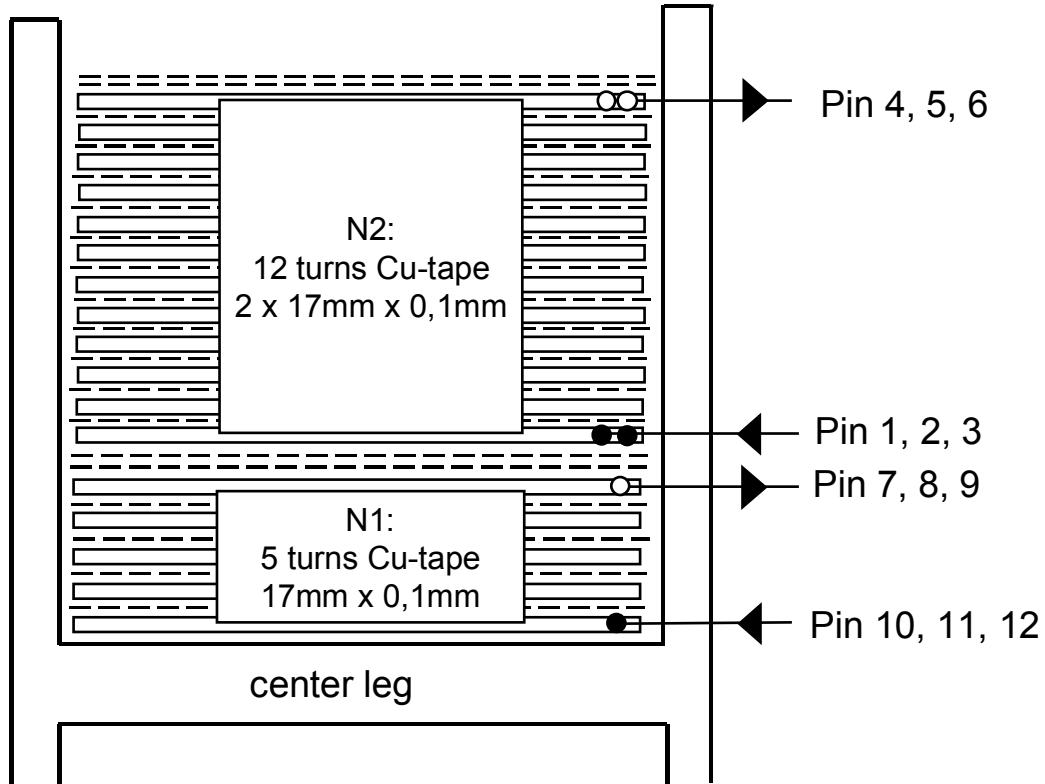

----- 1 layer Makrofol

N1 : 5 turns Cu-tape 17mm x 0,1mm
 N2 : 12 turns Cu-tape 17mm x 0,1mm

Hole arrangement
 View in mounting direction

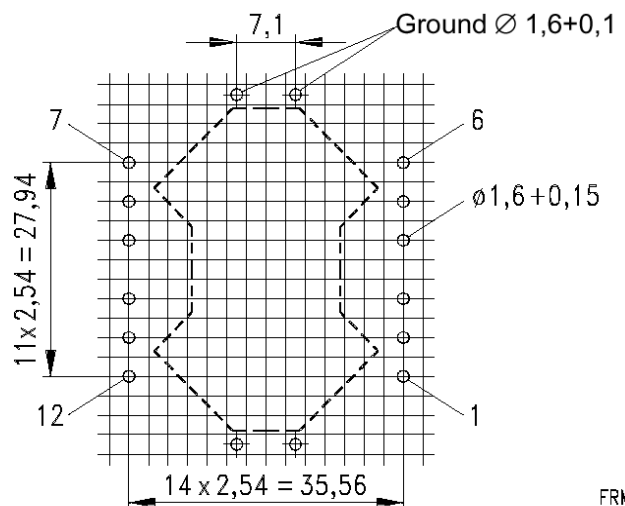

FRM1

9 PCB Layout

9.1 Main Board - Scaling 1:1

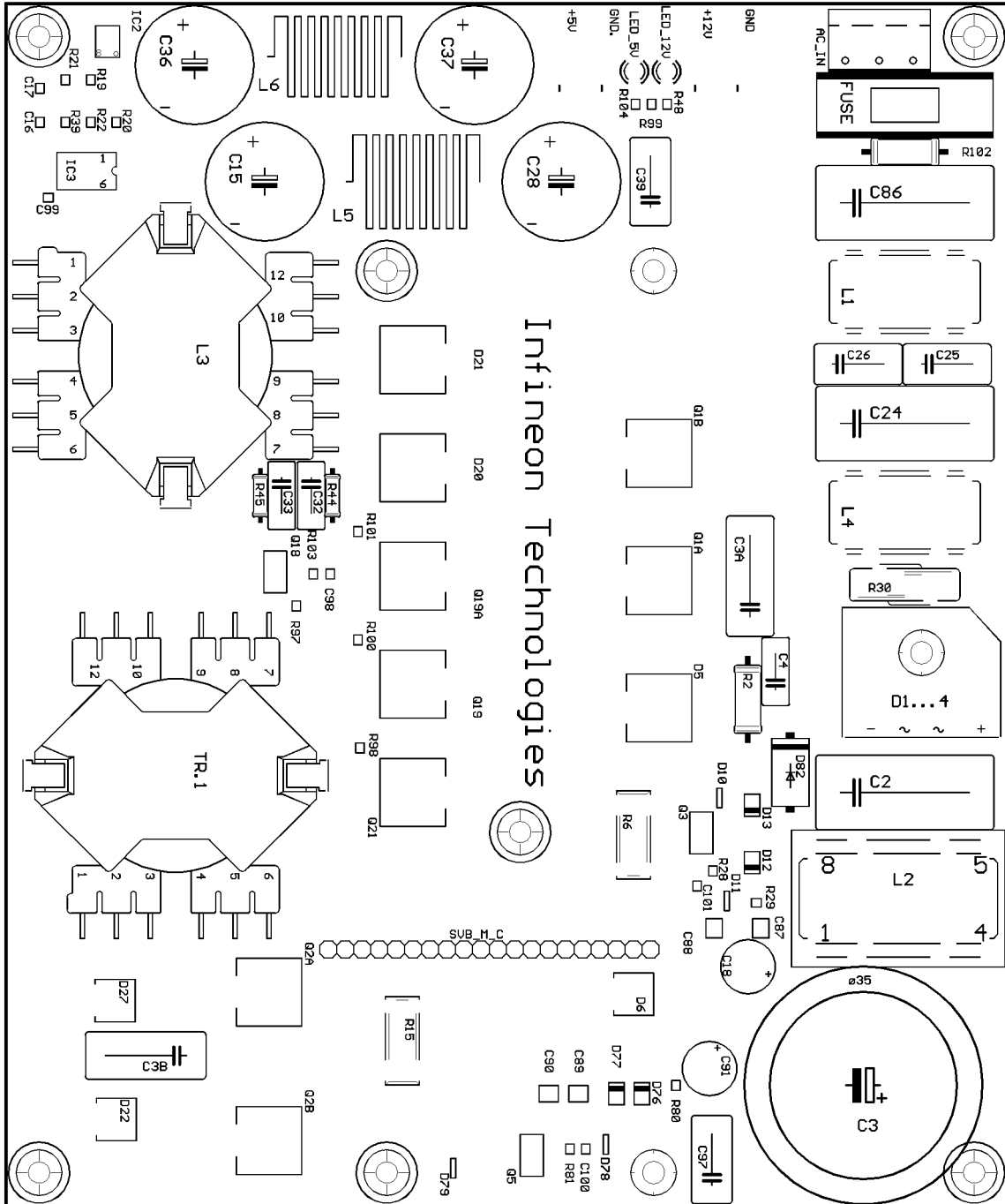

Main Board/ Top/ Components

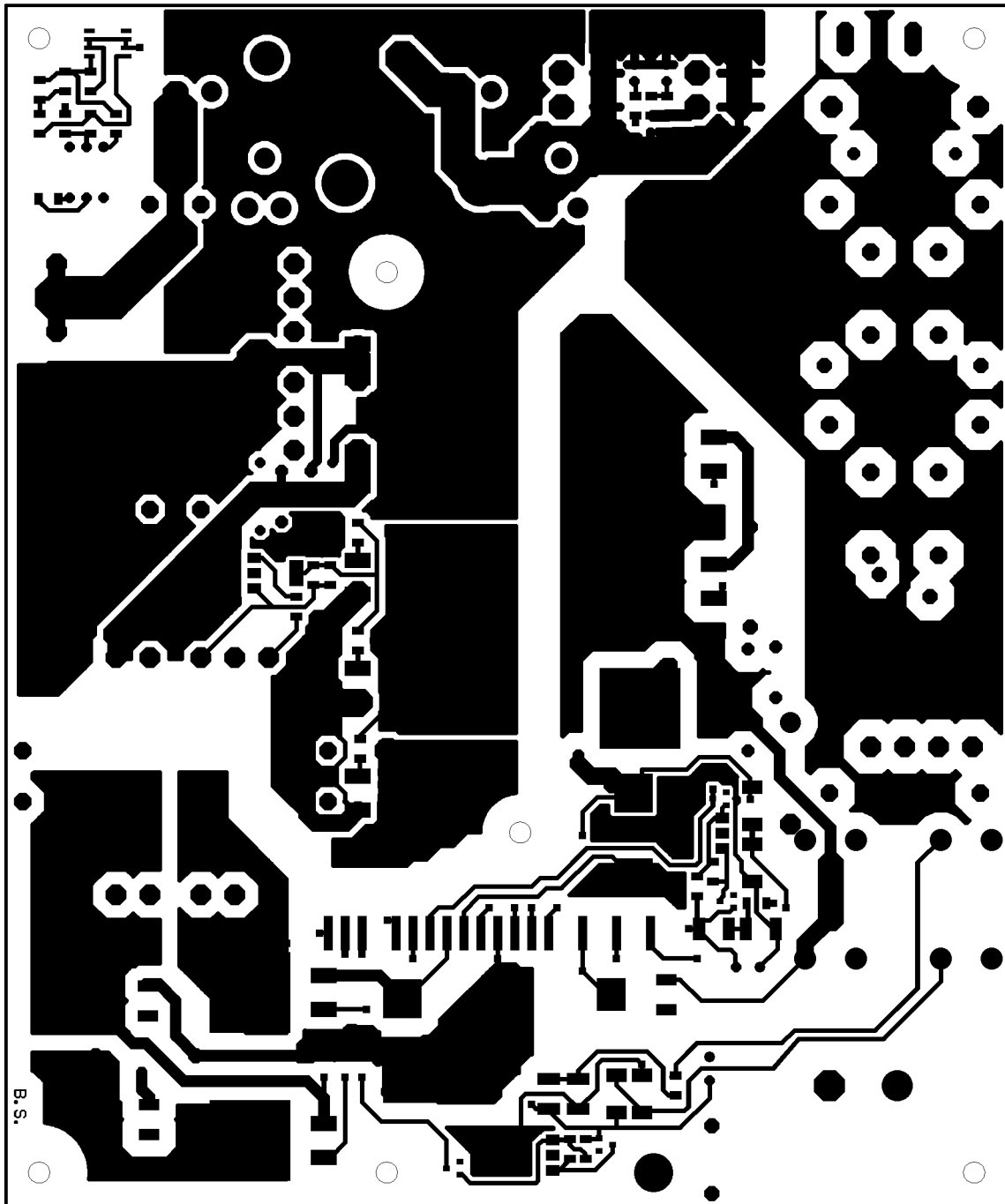

Main Board /Top / Copper

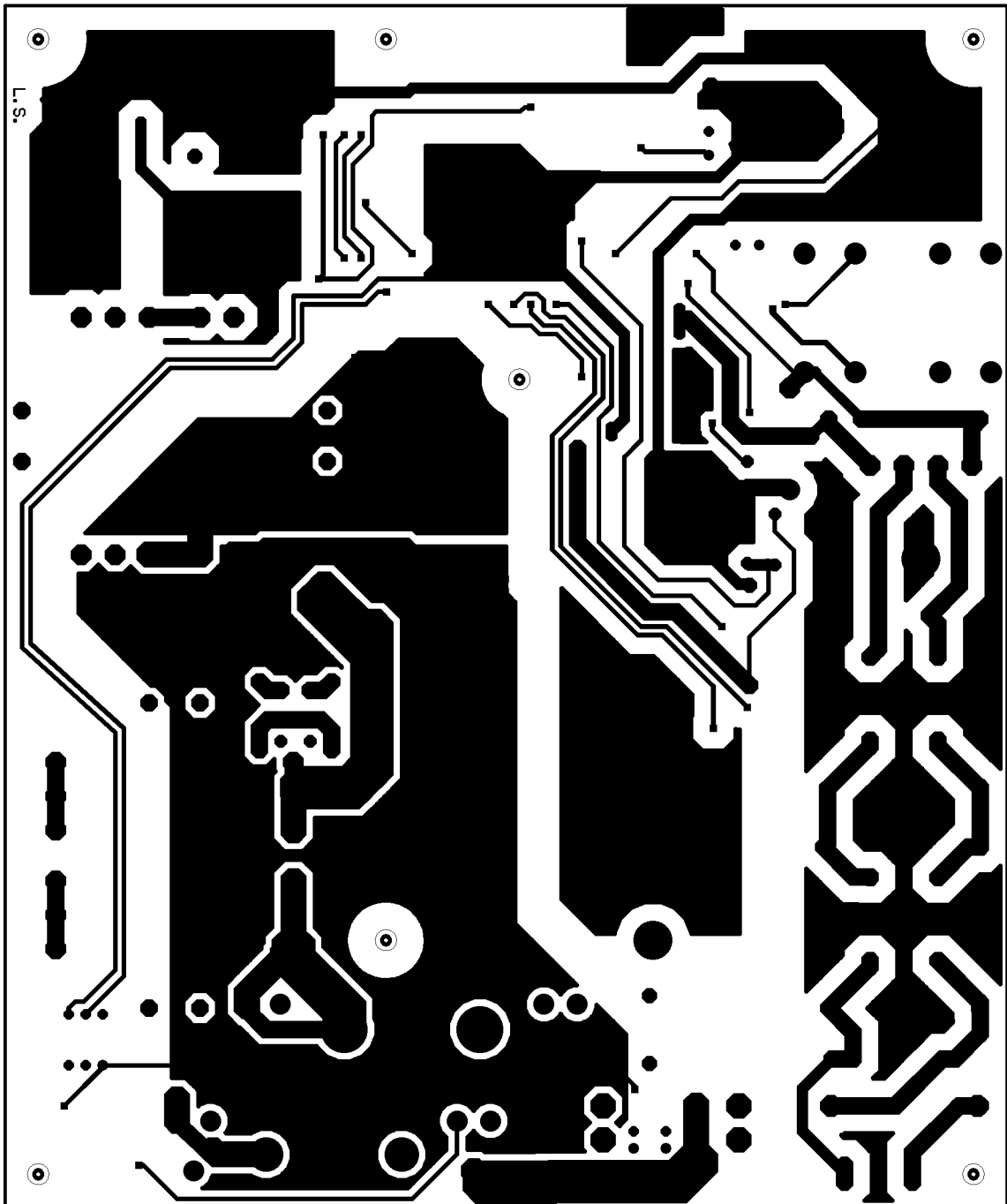

Main Board/ Bottom/ Bottom View/ Copper

9.2 Control Board- Scaling 1:1

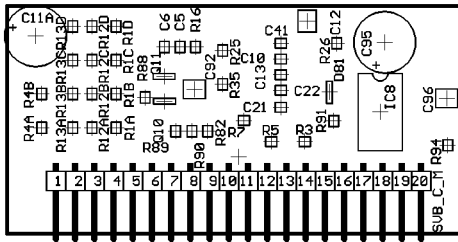

Control Board/ Top/ Components

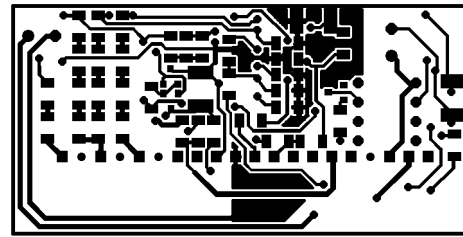

Control Board/ Top/ Copper

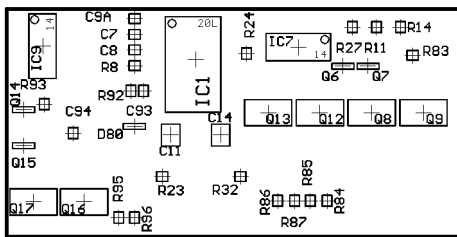

Control Board/ Bottom/ Bottom View/ Components

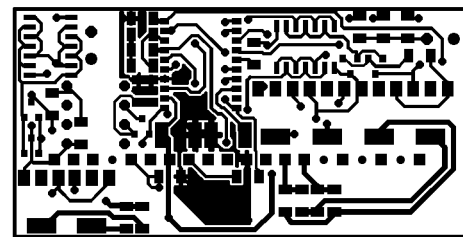

Control Board/ Bottom/ Bottom View/ Copper

10 Bill of Materials

10.1 Main Board

Part	Value	Package	Library	Position (mil)	Orientation
+5V		FLSTL6,3	CON-RIB	(500 3275)	R180
+12V		FLSTL6,3	CON-RIB	(500 4075)	R180
AC_IN		KLEMME-3	WAGO508	(200 5150)	R270
C2	u47/X2	C22,5B11	CAP-WI	(4650 5300)	R90
C3	150u/450V	EB35D	POLCAP	(6375 5053.74)	R270
C3A	100n/630V	C15B7	CAP-WI	(3375 4387.5)	R180
C3B	100n/630V	C15B7	CAP-WI	(6200 825)	R270
C4	2n2/1kV	C7,5B4	CAP-WI	(3937.5 4537.5)	R180
C15	2m2/16V	E3P-18	POLCAP	(1050 1525)	R90
C16	68n	1206	SMD	(700 200)	R0
C17	2n2	1206	SMD	(500 200)	R0
C18	47u/63V	E3,5-8	POLCAP	(5675 4375)	R270
C24	u47/X2	C22,5B11	CAP-WI	(2475 5300)	R90
C25	4n7/Y	C10B6	CAP-WI	(2125 5550)	R90
C26	4n7/Y	C10B6	CAP-WI	(2125 5025)	R90
C28	2m2/16V	E3P-18	POLCAP	(1050 3275)	R90
C32	2n2/1kV	C7,5B4	CAP-WI	(2900 1800)	R0
C33	2n2/1kV	C7,5B4	CAP-WI	(2900 1625)	R0

Part	Value	Package	Library	Position (mil)	Orientation
C36	1m/25V	E3P-18	POLCAP	(362.5 1112.5)	R90
C37	1m/25V	E3P-18	POLCAP	(362.5 2762.5)	R90
C39	4n7/Y	C10B6	CAP-WI	(1050 3800)	R180
C86	u47/X2	C22,5B11	CAP-WI	(1175 5300)	R90
C87	u47	1812	SMD	(5450 4450)	R270
C88	u47	1812	SMD	(5450 4175)	R90
C89	u47	1812	SMD	(6425 3375)	R0
C90	u47	1812	SMD	(6425 3200)	R0
C91	47u/63V	E3,5-8	POLCAP	(6275 4150)	R0
C97	4n7/Y	C10B6	CAP-WI	(6812.5 4162.5)	R180
C98	4n7	1206	SMD	(3362.5 1912.5)	R180
C99	2n2	1206	SMD	(1143.75 250)	R90
C100	100n	1206	SMD	(6750 3418.75)	R180
C101	100n	1206	SMD	(5200 4075)	R0
D1...4	KBU8K	KBU-L	RECTIF	(4375 5400)	R270
D5	SDB06S60	D2PAK	SMD-SPC	(4150 3925)	R180
D6	SDD04E60	DPAK	SMD-SPC	(5837.5 3700)	R180
D10	BAV99	SOT-23	SMD	(4681.25 4206.25)	R0
D11	BZX84C13	SOT-23	SMD	(5287.5 4250)	R0
D12	TMBYV10-60	MELF	SMD	(5062.5 4400)	R180
D13	TMBYV10-60	MELF	SMD	(4725 4400)	R180
D20	MBRB2545	D2PAK	SMD-SPC	(2737.5 2325)	R0
D21	MBRB2545	D2PAK	SMD-SPC	(2100 2325)	R0
D22	SDD04E60	DPAK	SMD-SPC	(6575 650)	R180
D27	SDD04E60	DPAK	SMD-SPC	(5875 642.52)	R180
D76	TMBYV10-60	MELF	SMD	(6425 3750)	R0
D77	TMBYV10-60	MELF	SMD	(6425 3600)	R0
D78	BZX84C13	SOT-23	SMD	(6725 3537.5)	R180
D79	BAV99	SOT-23	SMD	(6862.5 2637.5)	R0
D82	1N5408	DO201-15	DIODE	(4531.25 4625)	R0
E\$5		BO3,2-P	HOLES	(6889.76 3818.9)	R0
E\$9		BO3,2-P	HOLES	(1574.8 3818.9)	R0
FUSE	4AT	SH22	FUSE	(600 5300)	R90
GND		FLSTL6,3	CON-RIB	(500 4325)	R180
GND.		FLSTL6,3	CON-RIB	(500 3525)	R180
IC2	TL431CD	SO-8	SMD-IC	(250 600)	R180
IC3	CNY17-3	DIL06	OPTOCPL	(987.5 475)	R270
L1	2x1m2	82722J	IND-A	(1700 5300)	R90
L2	500u	INF-PFC	IND-A	(5275 5262.5)	R90
L3	36/6uH	RM14-12A	IND-B	(2075 1000)	R270
L4	2x1m2	82722J	IND-A	(3000 5300)	R90
L5	1u	INAIR20A	IND-A	(1050 2400)	R90
L6	1u	INAIR8A	IND-A	(312.5 1937.5)	R90

Part	Value	Package	Library	Position (mil)	Orientation
LED_5V	Green/LC	LED3	LED	(400 3706.25)	R180
LED_12V	Red	LED3	LED	(400 3893.75)	R180
Q1A	SPB11N60C2	D2PAK	SMD-SPC	(3400 3925)	R180
Q1B	SPB11N60C2	D2PAK	SMD-SPC	(2650 3925)	R180
Q2A	SPB11N60C2	D2PAK	SMD-SPC	(5862.5 1625)	R180
Q2B	SPB11N60C2	D2PAK	SMD-SPC	(6700 1625)	R180
Q3	BSP129	SOT-223	SMD	(4887.5 4100)	R180
Q5	BSP129	SOT-223	SMD	(6787.5 3100)	R180
Q18	BSP318	SOT-223	SMD	(3350 1587.5)	R0
Q19	SPB80N03S2L-03	D2PAK	SMD-SPC	(4012.5 2325)	R0
Q19A	SPB80N03S2L-03	D2PAK	SMD-SPC	(3375 2325)	R0
Q21	SPB80N03S2L-03	D2PAK	SMD-SPC	(4650 2325)	R0
R2	220k/2W	0411/15	R	(4100 4375)	R180
R6	0R15/1W	R-SMR	SMD-SPC	(4900 3700)	R180
R15	R47	R-SMR	SMD-SPC	(6112.5 2337.5)	R0
R19	5k1	1206	SMD	(450 500)	R180
R20	5k1	1206	SMD	(700 650)	R180
R21	10k	1206	SMD	(450 350)	R180
R22	680R	1206	SMD	(700 500)	R180
R28	4k7	1206	SMD	(5112.5 4168.75)	R0
R29	1R	1206	SMD	(5300 4425)	R90
R30	S14K275	S14K275	VARIST	(3425 5300)	R0
R39	1k	1206	SMD	(700 350)	R0
R44	4R7/0, 6W	0207/10	R	(2900 1925)	R0
R45	4R7/0, 6W	0207/10	R	(2900 1500)	R0
R48	1k8	1206	SMD	(593.7 3897.98)	R0
R80	1R	1206	SMD	(6375 3950)	R0
R81	4k7	1206	SMD	(6750 3325)	R0
R97	10R	1206	SMD	(3550 1712.5)	R180
R98	1R	1206	SMD	(4387.5 2087.5)	R0
R99	1k8	1206	SMD	(593.75 3806.25)	R0
R100	1R	1206	SMD	(3750 2075)	R0
R101	1R	1206	SMD	(3112.5 2075)	R0
R102	1M2/Netz	0411/15	R	(875 5300)	R90
R103	47R	1206	SMD	(3362.5 1812.5)	R0
R104	1k8	1206	SMD	(593.75 3712.5)	R0
S\$63		BO3, 2-P	HOLES	(3825 5400)	R0
SVB_M_C		1X20SMDI	PINHEAD	(5575 2850)	R270
TR.1		RM14-12A	IND-B	(4550 1000)	R0

10.2 Control Board

Part	Value	Package	Library	Position (mil)	Orientation
C5	47n	1206	SMD	(900 968.75)	R270
C6	100n	1206	SMD	(818.75 968.75)	R90
C7	220p	1206	SMD	(1699.36 1050)	MR0
C8	2n2	1206	SMD	(1699.36 968.75)	MR180
C9A	2n2	1206	SMD	(1699.36 1131.26)	MR180
C10	47p	1206	SMD	(1424.36 906.24)	R0
C11	u47	1812	SMD	(1511.85 528.12)	MR180
C11A	220u/25V	E3,5-8	POLCAP	(150 1025)	R0
C12	u47	1812	SMD	(1561.87 1103.13)	R0
C13	47p	1206	SMD	(1424.37 825)	R180
C14	u47	1812	SMD	(1252.48 528.12)	MR180
C21	100p	1206	SMD	(1424.37 656.25)	R180
C22	4n7	1206	SMD	(1424.37 743.75)	R180
C41	220p	1206	SMD	(1424.36 987.5)	R180
C92	u47	1812	SMD	(975 749.36)	R90
C93	100p	1206	SMD	(1653.13 756.25)	MR90
C94	100n	1206	SMD	(2018.75 537.5)	MR90
C95	47u/63V	E3,5-8	POLCAP	(1965.63 993.75)	R90
C96	u47	1812	SMD	(2287.5 703.13)	R90
D80	BAV99	SOT-23	SMD	(1700 571.87)	MR180
D81	BAV99	SOT-23	SMD	(1678.12 734.37)	R270
IC1	TDA16888	SO-20L	SMD-IC	(1380.61 918.75)	MR270
IC7	HEF40106BT	SO-14	SMD-IC	(849.36 981.25)	MR180
IC8	SFH6711	DIL-08	IC	(1943.11 631.25)	R270
IC9	HEF40106BT	SO-14	SMD-IC	(2175 988.14)	MR270
Q6	BC817	SOT-23	SMD	(618.75 884.38)	MR0
Q7	BC807	SOT-23	SMD	(487.5 884.38)	MR0
Q8	BSP613P	SOT-223	SMD	(468.11 643.75)	MR180
Q9	BSP320S	SOT-223	SMD	(199.36 643.75)	MR180
Q10	BC817	SOT-23	SMD	(818.75 687.5)	R0
Q11	BC807	SOT-23	SMD	(818.76 815.63)	R180
Q12	BSP613P	SOT-223	SMD	(736.86 643.75)	MR180
Q13	BSP320S	SOT-223	SMD	(1005.61 643.75)	MR180
Q14	BC817	SOT-23	SMD	(2275.01 659.37)	MR180
Q15	BC807	SOT-23	SMD	(2275 471.88)	MR180
Q16	BSP613P	SOT-223	SMD	(1961.86 181.25)	MR180
Q17	BSP320S	SOT-223	SMD	(2224.35 181.25)	MR180
R1A	1M	1206	SMD	(568.11 550)	R90
R1B	1M	1206	SMD	(568.11 725)	R90
R1C	1M	1206	SMD	(568.11 900)	R90
R1D	820k	1206	SMD	(568.11 1075)	R90

Part	Value	Package	Library	Position (mil)	Orientation
R3	10k	1206	SMD	(1549.36 478.13)	R0
R4A	470k	1206	SMD	(180.61 550)	R90
R4B	470k	1206	SMD	(180.61 725)	R90
R5	1k8	1206	SMD	(1374.36 478.13)	R180
R7	1k8	1206	SMD	(1233.74 587.5)	R0
R8	10k	1206	SMD	(1699.36 887.5)	MR0
R11	51k	1206	SMD	(443.75 1087.5)	MR90
R12A	1M	1206	SMD	(443.11 550)	R90
R12B	1M	1206	SMD	(443.11 725)	R90
R12C	1M	1206	SMD	(443.11 900)	R90
R12D	820k	1206	SMD	(443.11 1075)	R90
R13A	1M	1206	SMD	(343.11 550)	R90
R13B	1M	1206	SMD	(343.11 725)	R90
R13C	1M	1206	SMD	(343.11 900)	R90
R13D	820k	1206	SMD	(343.11 1075)	R90
R14	51k	1206	SMD	(318.75 1087.5)	MR90
R16	390k	1206	SMD	(981.26 968.75)	R270
R23	33k	1206	SMD	(1556.25 312.5)	MR0
R24	22k	1206	SMD	(1118.75 950)	MR270
R25	10k	1206	SMD	(1121.87 950)	R270
R26	33k	1206	SMD	(1714.98 987.5)	R90
R27	51k	1206	SMD	(568.76 1087.5)	MR90
R32	1k	1206	SMD	(1150 312.5)	MR0
R35	1k	1206	SMD	(1121.87 775)	R90
R82	10R	1206	SMD	(1043.75 531.26)	R90
R83	4R7	1206	SMD	(256.25 940.63)	MR0
R84	22R	1206	SMD	(700 187.5)	MR270
R85	4R7	1206	SMD	(787.5 187.5)	MR270
R86	22R	1206	SMD	(956.25 187.5)	MR270
R87	4R7	1206	SMD	(868.75 187.5)	MR270
R88	4R7	1206	SMD	(718.75 706.25)	R270
R89	22R	1206	SMD	(878.13 531.25)	R90
R90	4R7	1206	SMD	(962.5 531.25)	R90
R91	1k	1206	SMD	(1700.01 584.38)	R90
R92	1k	1206	SMD	(1718.76 756.25)	MR90
R93	10R	1206	SMD	(2168.75 687.5)	MR90
R94	4R7	1206	SMD	(2293.75 459.38)	R90
R95	22R	1206	SMD	(1781.25 100)	MR90
R96	4R7	1206	SMD	(1700 100)	MR90
SVB_C_M		1X20/90I	PINHEAD	(1205.61 400)	R0

This demonstration board was designed by



ISLE GmbH
Ehrenbergstr. 33
98693 Ilmenau
Germany

Revision History		
Application Note AN-CoolMOS-06		
Actual Release: V1.2 Date:2001-11-14		Previous Release: V1.1
Page of actual Release	Page of prev. Release	Subjects changed since last release
		Construction of magnetic components added.

For questions on technology, delivery and prices please contact the Infineon Technologies Offices in Germany or the Infineon Technologies Companies and Representatives worldwide: see the address list on the last page or our webpage at

<http://www.infineon.com>

CoolMOS™ and CoolSET™ are trademarks of Infineon Technologies AG.

Edition 2000-03-03

Published by Infineon Technologies AG,
St.-Martin-Strasse 53,
D-81541 München

© Infineon Technologies AG 2000.

All Rights Reserved.

Attention please!

The information herein is given to describe certain components and shall not be considered as warranted characteristics.

Terms of delivery and rights to technical change reserved.

We hereby disclaim any and all warranties, including but not limited to warranties of non-infringement, regarding circuits, descriptions and charts stated herein.

Infineon Technologies is an approved CECC manufacturer.

Information

For further information on technology, delivery terms and conditions and prices please contact your nearest Infineon Technologies Office in Germany or our

Infineon Technologies Representatives worldwide (see address list).

Warnings

Due to technical requirements components may contain dangerous substances. For information on the types in question please contact your nearest Infineon Technologies Office.

Infineon Technologies Components may only be used in life-support devices or systems with the express written approval of Infineon Technologies, if a failure of such components can reasonably be expected to cause the failure of that life-support device or system, or to affect the safety or effectiveness of that device or system. Life support devices or systems are intended to be implanted in the human body, or to support and/or maintain and sustain and/or protect human life. If they fail, it is reasonable to assume that the health of the user or other persons may be endangered.

Infineon Technologies AG sales offices worldwide partly represented by Siemens AG

<p>A Siemens AG Österreich Erdberger Lände 26 A-1031 Wien T (+43)1-17 07-3 56 11 Fax (+43)1-17 07-5 59 73</p> <p>AUS Siemens Ltd. 885 Mountain Highway Bayswater, Victoria 3153 T (+61)3-97 21 21 11 T (+61)3-97 21 72 75</p> <p>B Siemens Electronic Components Benelux Charleroisesteenweg 116/ Chaussée de Charleroi 116 B-1060 Brussel/Bruxelles T (+32)2-5 36 69 05 Fax (+32)2-5 36 28 57 Email: components@siemens.nl</p> <p>BR Siemens Ltda. Semicondutores Avenida Mutinga, 3800-Pirituba 05110-901 São Paulo-SP T (+55)11-39 08 25 64 Fax (+55)11-39 08 27 28</p> <p>CDN Infineon Technologies Corporation 320 March Road, Suite 604 Canada, Ontario K2K 2E2 T (+1)6 13-5 91 63 86 Fax (+1)6 13-5 91 63 89</p> <p>CH Siemens Schweiz AG Bauelemente Freilagerstrasse 40 CH-8047 Zürich T (+41)1-4 953065 Fax (+41)1-4 955050</p> <p>D Infineon Technologies AG Völklinger Str.2 D-40219 Düsseldorf T (+49)2 11-3 99 29 30 Fax (+49)2 11-3 99 14 81</p> <p>Infineon Technologies AG Werner-von-Siemens-Platz 1 D-30880 Laatzen (Hannover) T (+49)5 11-8 77 22 22 Fax (+49)5 11-8 77 15 20</p> <p>Infineon Technologies AG Von-der-Tann-Straße 30 D-90439 Nürnberg T (+49)9 11-6 54 76 99 Fax (+49)9 11-6 54 76 24</p> <p>Infineon Technologies AG Weissacher Straße 11 D-70499 Stuttgart T (+49)7 11-1 37 33 14 Fax (+49)7 11-1 37 24 48</p> <p>D Infineon Technologies AG Halbleiter Distribution Richard-Strauss-Straße 76 D-81679 München T (+49)89-92 21 40 86 Fax (+49)89-92 21 20 71</p> <p>DK Siemens A/S Borupvang 3 DK-2750 Ballerup T (+45)44 77-44 77 Fax (+45)44 77-40 17</p> <p>E Siemens S.A. Dpto. Componentes Ronda de Europa, 5 E-28760 Tres Cantos-Madrid T (+34)91-5 14 71 51 Fax (+34)91-5 14 70 13</p>	<p>F Infineon Technologies France, 39/47, Bd.Ornano F-93527 Saint-Denis CEDEX2 T (+33)1-49 22 31 00 Fax (+33)1-49 22 28 01</p> <p>FIN Siemens Components Scandinavia P.O. Box 6 0 FIN-02601 Espoo (Helsinki) T (+3 58)10-5 11 51 51 Fax (+3 58)10-5 11 24 95 Email: scs@components.siemens.se</p> <p>GB Infineon Technologies Siemens House Oldbury GB-Bracknell, Berkshire RG12 8FZ T (+44)13 44-39 66 18 Fax (+44)13 44-39 66 32</p> <p>H Simacomp Kft. Lajos u.103 H-1036 Budapest T (+36)1-4 57 16 90 Fax (+36)1-4 57 16 92</p> <p>HK Infineon Technologies Hong Kong Ltd. Suite 302, Level 3, Festival Walk, 80 Tat Chee Avenue, Yam Yat Tsuen, Kowloon Tong Hong Kong T (+8 52)28 32 05 00 Fax (+8 52)28 27 97 62</p> <p>I Siemens S. A. Semiconductor Sales Via Piero e Alberto Pirelli, 10 I-20126 Milano T (+39)02-66 76 -1 Fax (+39)02-66 76 43 95</p> <p>IND Siemens Ltd. Components Division No.84 Keonics Electronic City Hosur Road Bangalore 561 229 T (+91)80-8 52 11 22 Fax (+91)80-8 52 11 80</p> <p>Siemens Ltd. CMP Div, 5th Floor 4A Ring Road, IP Estate New Delhi 110 002 T (+91)11-3 31 99 12 Fax (+91)11-3 31 96 04</p> <p>Siemens Ltd. CMP Div, 4th Floor 130, Pandurang Budhkar Marg, Worli Mumbai 400 018 T (+91)22-4 96 21 99 Fax (+91)22-4 96 22 01</p> <p>IRL Siemens Ltd. Electronic Components Division 8, Raglan Road IRL-Dublin 4 T (+3 53)1-2 16 23 42 Fax (+3 53)1-2 16 23 49</p> <p>IL Nisko Ltd. 2A, Habarzel St. P.O.Box 58151 61580 Tel Aviv -Israel T (+9 72)3 -7 65 73 00 Fax (+9 72)3 -7 65 73 33</p>	<p>J Siemens Components K.K. Talanawa Park Tower 12F &17F 3-20-14, Higashi-Gotanda, Shinagawa-ku Tokyo T (+81)3-54 49 64 11 Fax (+81)3 -54 49 64 01</p> <p>MAL Infineon Technologies AG Sdn Bhd Bayan Lepas Free Industrial Zone1 11900 Penang T (+60)4 -6 44 99 75 Fax (+60)4 -6 41 48 72</p> <p>N Siemens Components Scandinavia Østre Aker vei 24 Postboks 10, Veitvet N-0518 Oslo T (+47)22-63 30 00 Fax (+47)22-68 49 13 Email: scs@components.siemens.se</p> <p>NL Siemens Electronic Components Benelux Postbus 16068 NL-2500 BB Den Haag T (+31)70-3 33 20 65 Fax (+31)70-3 33 28 15 Email: components@siemens.nl</p> <p>NZ Siemens Auckland 300 Great South Road Greenland Auckland T (+64)9-5 20 30 33 Fax (+64)9-5 20 15 56</p> <p>P Siemens S.A. an Componentes Electronicos R.Irmaos Siemens, 1 Alfragide P-2720-093 Amadora T (+351)1-4 17 85 90 Fax (+351)1-4 17 80 83</p> <p>PK Siemens Pakistan Engineering Co.Ltd. PO Box 1129, Islamabad 44000 23 West Jinnah Ave Islamabad T (+92)51-21 22 00 Fax (+92)51-21 16 10</p> <p>PL Siemens SP.z.o.o. ul.Zupnicza 11 PL-03-821 Warszawa T (+48)22-8 70 91 50 Fax (+48)22-8 70 91 59</p> <p>ROK Siemens Ltd. Asia Tower, 10th Floor 726 Yeoksam-dong, Kang-nam Ku CPO Box 3001 Seoul 135-080 T (+82)2-5 27 77 00 Fax (+82)2-5 27 77 79</p> <p>RUS INTECH electronics ul.Smolnaya, 24/1203 RUS-125 445 Moskva T (+7)0 95 -4 51 97 37 Fax (+7)0 95 -4 51 86 08</p> <p>S Siemens Components Scandinavia Österögatan 1, Box 46 S-164 93 Kista T (+46)8-7 03 35 00 Fax (+46)8-7 03 35 01 Email: scs@components.siemens.se</p>	<p>RC Infineon Technologies Asia Pacific Pte.Ltd. Taiwan Branch 10F, No.136 Nan King East Road Section 23, Taipei T (+8 86)2-27 73 66 06 Fax (+8 86)2-27 71 20 76</p> <p>SGP Infineon Technologies Asia Pacific, Pte.Ltd. 168 Kallang Way Singapore 349 253 T (+65)8 40 06 10 Fax (+65)7 42 62 39</p> <p>USA Infineon Technologies Corporation 1730 North First Street San Jose, CA 95112 T (+1)4 08-5 01 60 00 Fax (+1)4 08-5 01 24 24</p> <p>Siemens Components, Inc. Optoelectronics Division 19000 Homestead Road Cupertino, CA 95014 T (+1)4 08-2 57 79 10 Fax (+1)4 08-7 25 34 39</p> <p>Siemens Components, Inc. Special Products Division 186 Wood Avenue South Iselin, NJ 08830-2770 T (+1)7 32-9 06 43 00 Fax (+1)7 32-6 32 28 30</p> <p>VRC Infineon Technologies Hong Kong Ltd. Beijing Office Room 2106, Building A Vantone New World Plaza No.2 Fu Cheng Men Wai Da Jie Jie 100037 Beijing T (+86)10 -68 57 90 -06,-07 Fax (+86)10 -68 57 90 08</p> <p>Infineon Technologies Hong Kong Ltd. Chengdu Office Room14J1, Jinyang Mansion 58 Tidu Street Chengdu, Sichuan Province 610 016 T (+86)28-6 61 54 46 /79 51 Fax (+86)28 -6 61 01 59</p> <p>Infineon Technologies Hong Kong Ltd. Shanghai Office Room1101, Lucky Target Square No.500 Chengdu Road North Shanghai 200003 T (+86)21-63 6126 18 /19 Fax (+86)21-63 61 11 67</p> <p>Infineon Technologies Hong Kong Ltd. Shenzhen Office Room 1502, Block A Tian An International Building Renim South Road Shenzhen 518 005 T (+86)7 55-2 28 91 04 Fax (+86)7 55-2 28 02 17</p> <p>ZA Siemens Ltd. Components Division P.O.B.3438 Halfway House 1685 T (+27)11-6 52 -27 02 Fax (+27)11-6 52 20 42</p>
--	---	--	---